

COLDTECH

REFRIGERATION
HARDWARE
2023



Catalogo componenti
Spare-parts catalogue
Catalogue pieces detachees
Catalogo de componente



Sommario

PORTE TIPO UFFICIO OFFICE DOOR / TYPE BUREAU / TIPO OFICINA	4
PORTE SCORREVOLI MANUALI MANUAL SLIDING DOORS / PORTES COULISSANTES MANUELS / PUERTAS CORREDIZAS MANUALES	8
PORTE SCORREVOLI LEGGERE MANUAL SLIDING DOORS / PORTES COULISSANTES MANUELS / PUERTAS CORREDIZAS MANUALES	10
PORTE VA E VIENI PUSH & PULL DOORS / PORTES VA-ET-VIEN / PUERTAS DE VAIVÉN	12
ATMOSFERA CONTROLLATA CONTROLLED ATMOSPHERE / ATMOSPHERE CONTRÔLÉ / ATMÓSFERA CONTROLADA ...	15
PROFILI IN ALLUMINIO ALUMINIUM PROFILES / PROFILS ALLUMINIUM / PERFILES ALUMINIO	17
PROFILI IN PVC PVC PROFILES / PROFILS PVC / PERFILES IN PVC	20
GUARNIZIONI GASKET / JOINT / BURLETE	23
MANIGLIE HANDLES / POIGNÉES / MANIJAS	26
ACCESSORI PLASTICA PER PORTE SCORREVOLI PLASTIC ACCESSORIES FOR SLIDING DOORS / ACCESSOIRES PLASTIQUE PORTES COULISSANTES / ACCESORIOS DE PLÁSTICO PUERTAS CORREDERAS	33
CERNIERE DOOR ACCESSORIES / ACCESSOIRES PORTES / ACCESORIOS PUERTAS	41
RINFORZI REINFORCEMENTS/ RENFORTS/ REFUERZOS	43
VALVOLE DI COMPENSAZIONE COMPENSATION VALVES / SOUPAPES POUR CHAMBRE FROIDES / VALVOLA COMPENSADORA	44
RESISTENZE HEATER / CORDON CHAUFFANT / RESISTENCIA	45
AUTOMATION COMPONENTS	
PORTE SCORREVOLI MANUALI MANUAL SLIDING DOORS / PORTES COULISSANTES MANUELS / PUERTAS CORREDIZAS MANUALES	55
PORTE SU CERNIERA DOORS ON HINGES / PORTES SUR CHARNIÈRE / PUERTAS SOBRE BISAGRA	60
PORTE UFFICIO OFFICE DOORS / PORTES BUREAUX / PUERTAS OFICIO	64
PORTE VA E VIENI PUSH & PULL DOORS / PORTES VA-ET-VIEN / PUERTAS DE VAIVÉN	66

SELO00006

- telaio per Tipo Ufficio per pannelli spessore 60 mm
- frame profile for Office Door for pannel tk 60 mm
- profil bati pour Type Bureau pour panneaux ep 60 mm
- perfil marco para puerta tipo oficina per paneles ep 60 mm

L = 6000 mm

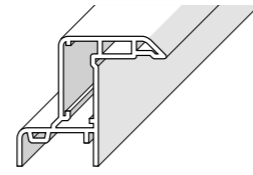

SELO00007

- controtelaio per Tipo Ufficio per pannelli spessore 60 mm
- counter frame profile for Office Door or pannel tk 60 mm
- contre cadre pour Type Bureau pour panneaux ep 60 mm
- contromarco para puerta tipo oficina per paneles ep 60 mm

L = 6000 mm

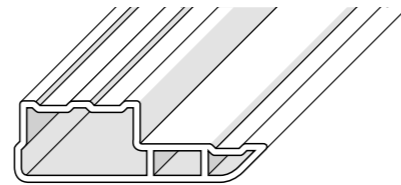

COM404020

- distanziale 40 x 40 mm
- profile spacer 40 x 40 mm
- espaceur profil 40 x 40 mm
- perfil distanciados 40 x 40 mm

L = 6000 mm

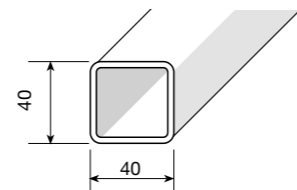

COM402020

- distanziale 40 x 20 mm
- profile spacer 40 x 20 mm
- espaceur profil 40 x 20 mm
- perfil distanciados 40 x 20 mm

L = 6000 mm

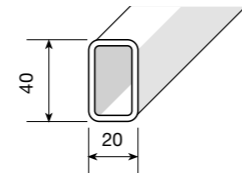

COM403020

- distanziale 40 x 30
- profile spacer 40 x 30
- espaceur profil 40 x 30
- perfil distanciador 40 x 30

L = 6000 mm

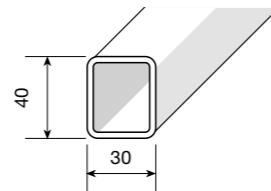

COM405020

- distanziale 40 x 50 x 2
- profile spacer 40 x 50 x 2
- espaceur profil 40 x 50 x 2
- perfil distanciador 40 x 50 x 2

L = 6000 mm

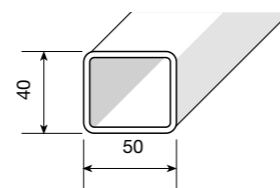

COM604020

- distanziale 40 x 60 x 2
- profile spacer 40 x 60 x 2
- espaceur profil 40 x 60 x 2
- perfil distanciador 40 x 60 x 2

L = 6000 mm

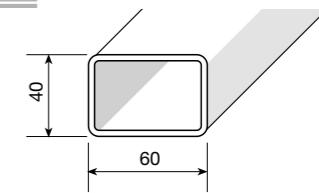

COM804020

- distanziale 40 x 80 x 2
- profile spacer 40 x 80 x 2
- espaceur profil 40 x 80 x 2
- perfil distanciador 40 x 80 x 2

L = 6000 mm

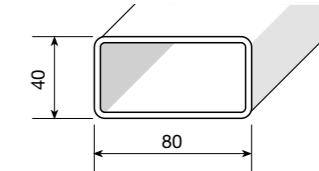

SELO00008

- bordo battente da 40 mm
- door leaf profile 40 mm
- bord vantail 40 mm
- perfil bordo batiente

L = 6000 mm

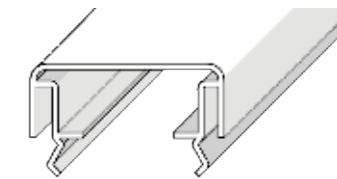

SELO00026

- bordo battente non schiumato da 40 mm
- door leaf profile not injected 40 mm
- bord vantail pas injectè 40 mm
- perfil bordo batiente no inyecta 40 mm

L = 6000 mm

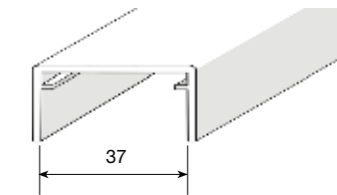

TMP000003

- guarnizione perimetrale
- perimetral gasket
- joint d'etancheite perimetral
- junta hermetica perimetral

L = Rotolo 125 m

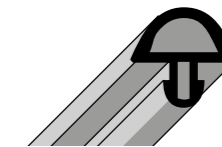

TMP000011

- profilo guida per guarnizione tipo ufficio inox
- guide for office door gasket ss
- profil porte joint en pvc pour portes service inox
- perfil para burlete puertas servicio inox

L = 2000 m

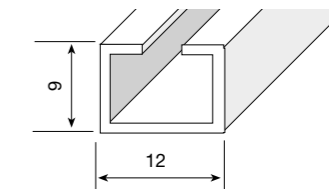

6904004000003

- oblò 25X75 senza guarnizione
- porthole 25X75 without gasket
- hublot 25X75 sans joint
- ventanilla 25X75 sin burlete

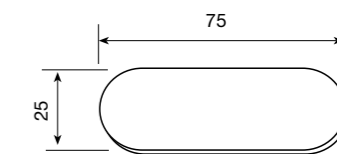

6904004000012

- oblò 25X75 con guarnizione
- porthole 25X75 with gasket
- hublot 25X75 avec joint
- ventanilla 25X75 con burlete

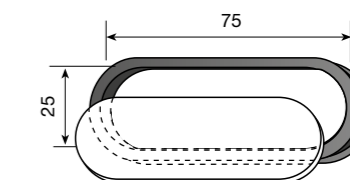

PORTE TIPO UFFICIO

OFFICE DOOR / TYPE BUREAU / TIPO OFICINA

COLDTECH

ODA0000004

- maniglia ufficio acciaio inox satinato
- handle for office door inox satin
- poignée port de service en inox satiné
- macaneta puertas tipo oficina in acciaio inox

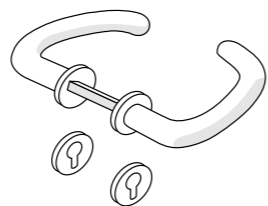

ODA0000005

- maniglia ufficio alluminio anodizzato argento
- handle for office door anodizing silver
- poignée port de service anode d'argent
- macaneta puertas tipo oficina in alum. anod. arg.

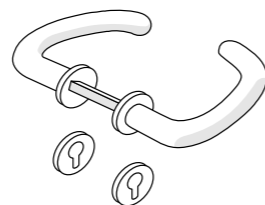

ODA0000008

- maniglia ufficio alluminio color inox
- handle for office door in aluminium color inox
- poignée port de service en aluminium couleur inox
- macaneta puertas tipo oficina in alum. color inox

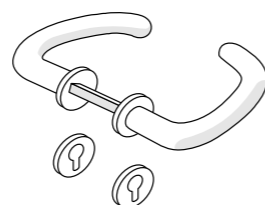

ODA0000003NEW

- serratura di sicurezza ent.60 inox bordo e catenaccio ottone. Nuovo modello
- security lock op. 60 inox board and brass bolt. New model
- fermeture de sécurité 60 inox avec pointe et boulon en laiton. Nouveau modèle
- cierre puerta 60 inox. Nuevo modelo

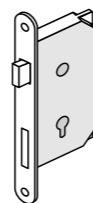

ODA0000007NEW

- serratura libero/occupato
- "wc" service door lock
- serrure "wc" pour porte Type bureau
- serradura "wc" para puerta tipo oficina

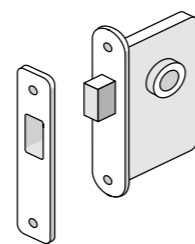

ODA0000012

- dispositivo libero/occupato
- "wc" device
- dispositif "wc"
- mecanismo "wc"

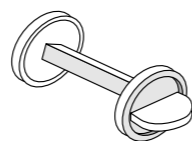

ODA0000009

- cilindri in ottone nichelato mm 60 22/10/28
- lock with key mm 60 22/10/28
- bloc serrure avec clés mm 60 22/10/28
- cerradura con llave mm 60 22/10/28

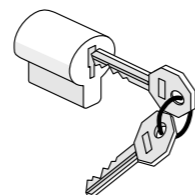

6

PORTE TIPO UFFICIO

OFFICE DOOR / TYPE BUREAU / TIPO OFICINA

COLDTECH

ATP0000001

- dispositivo interno di apertura con maniglione a barra
- inside release with bar device
- barre a pousser de secours
- dispositivo interno de apertura con tirador de barra

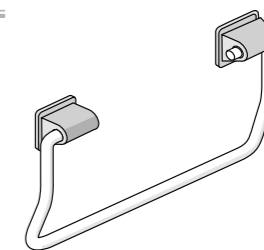

ATP0000010

- maniglione antipanico
- panic-bar
- barre antipanique
- barra antipanico



ODA0000006

- squadrette 24x14
- corner bracket for frame 24x14
- cerniere a vis pour bati
- esquadra para marco

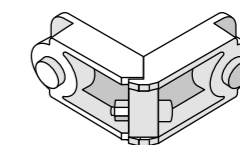

OMIPV000008

- vaschetta raccogliacqua differenziate
- water drip trough with different deep set
- gaches pour portes de services avec different profondeur
- bandeja de recogida de agua con cubitas diferentes

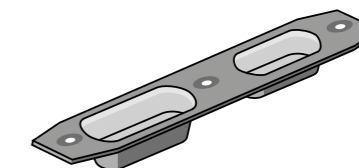

OMIPV000010

- vaschetta raccogliacqua con vaschette uguali
- water drip trough with same deep set
- gaches pour portes de services avec le meme profondeur
- bandeja de recogida de agua con cubitas iguales



6909004000027CT/ 28CT

- cerniera in alluminio per porte tipo ufficio ds/sx
- hinges in aluminium for office door rh/lh
- charniere en aluminium pour porte by bureau dr/go
- bisagras in aluminio para porta tipo oficina ds/lh

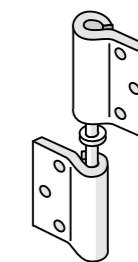

OMIPV000006

- angolare unione controtelaio
- connecting angle for counter frame
- corniere d'accouplement pour contre cadre
- angulo union para contromarco

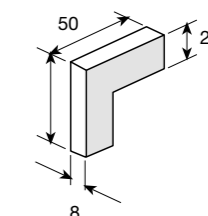

7

PORTE SCORREVOLI MANUALI

MANUAL SLIDING DOORS / PORTES COULISSANTES MANUELS / PUERTAS CORREDIZAS MANUALES

COLDTECH

SELO00001

- binario per guida superiore
- *track for upper guide*
- rail pour guide supérieur
- *riel para guía superior*

- TN65 - TN95 - BT95
- BT120 - BT140 L = 6000 mm

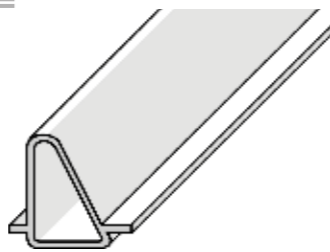

SELO00034

- binario per guida superiore rinforzato
- *track for upper guide reinforced*
- rail pour guide supérieur renforcé
- *riel para guía superior reforzado*

- TN65 - TN95 - BT95
- BT120 - BT140 L = 7000 mm

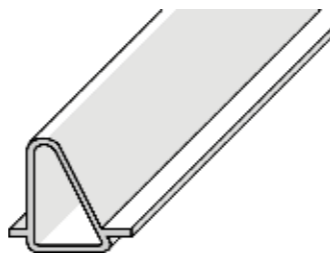

SELO00002

- guida inferiore
- *lower guide*
- guide inférieur
- *guía inferior*

- TN65 - TN95 - BT95
- BT120 - BT140 L = 6000 mm

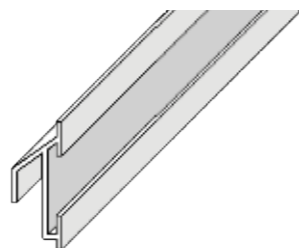

SELO00029

- guida inferiore nuovo tipo rinforzato
- *lower guide new type reinforced*
- guide inférieur nouveau type renforcé
- *guía inferior nueva reforzado*

- TN65 - TN95 - BT95
- BT120 - BT140 L = 6000 mm



SELO00003

- supporto binario per guida superiore
- *track support for upper guide*
- support rail pour guide supérieur
- *soporte riel para guía superior*

- TN65 - TN95 - BT95
- BT120 - BT140 L = 6000 mm

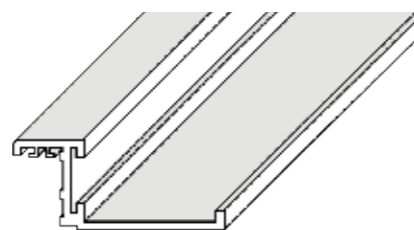

SELO00004

- rinforzo per guida superiore
- *reinforcement for upper guide*
- renfort pour guide supérieur
- *refuerzo para guía superior*

- TN65 - TN95 - BT95
- BT120 - BT140 L = 6000 mm

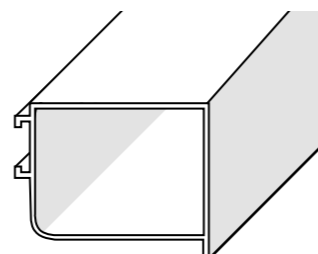

8

PORTE SCORREVOLI MANUALI

MANUAL SLIDING DOORS / PORTES COULISSANTES MANUELS / PUERTAS CORREDIZAS MANUALES

COLDTECH

6901021000034

- supporto copertina
- *cover support*
- support couverture
- *soporte cubierta*

- TN65 - TN95 - BT95
- BT120 - BT140 L = 7000 mm



6901021000037

- copertina per porta scorrevole
- *cover for sliding door*
- couverture pour porte coulissante
- *cubierta para puerta corredera*

- TN65 - TN95 - BT95
- BT120 - BT140 L = 7000 mm



6901021000017

- contro telaio alluminio in color argento
- *counter frame aluminium in silver color*
- contre chassis aluminium en couleur argent
- *contra marco aluminio en color plata*

- TN65 - TN95 - BT95
- BT120 - T140 L = 6500 mm



6901021000071

- contro telaio alluminio per pannelli di spessore dispari
- *aluminium counter frame for odd-numbered panel thickness*
- contre chassis aluminium pour panneaux d'épaisseur impair
- *contra marco aluminio para paneles espesor impar*

- TN65 - TN95 - BT95
- BT120 - T140 L = 6500 mm

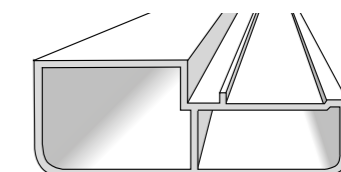

9

SEL000025

- profilo binario 240
 - track profile for 240 door
 - profil rail pour porte 240
 - perfil rail pra puerta 240
- L = 6000 mm**

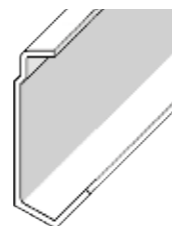

CT14061

- carrucola alluminio "dx"
- aluminium pulley right
- poulie droite en alu droit
- polea aluminio derecha

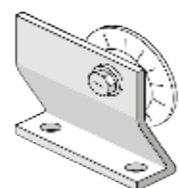

CT14062

- carrucola alluminio "sx"
- aluminium pulley left
- poulie droite en alu gauche
- polea aluminio izquierda

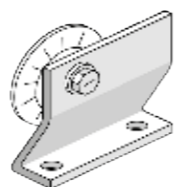

CT14061NM

- carrucola alluminio "dx" nuovo modello
- aluminium pulley right - new model
- poulie droite en alu droit - nouveau modèle
- polea aluminio derecha - nuevo modelo

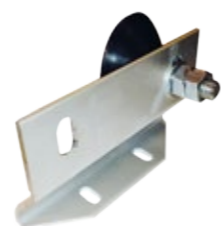

CT14062NM

- carrucola alluminio "sx" - nuovo modello
- aluminium pulley left - new model
- poulie droite en alu gauche - nouveau modèle
- polea aluminio izquierda - nuevo modelo



SEL000033

- guida inferiore nel battente
 - lower guide into the blade
 - guide inférieur dans le vantail
 - guía inferior ne la oja
- **BT140** **L = 6000 mm**



OMIPV00019

- fine corsa per porta 240
- r/h opening limit stop x 240 door
- arrêt course pour portes 240
- fin de carrera para puertas 240

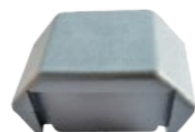

TORM000008

- Registro per nuova guida inferiore (abbinato a SEL000033)
- Register for new lower guide (to be assembled with SEL000033)
- Registre pour nouveau guide inférieur (a monter avec SEL000033)
- Regulador guía inferior nueva (armar con SEL000033)



CT16036

- guida a pavimento con cuscinetto e viti
- floor guide with ball bearings and screws
- guide au sol avec roulements billes et vis
- guía a pavimento con rodaminetos y tornillos

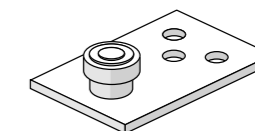

CT16036B

- guida a pavimento con cuscinetto ed asole
- floor guide with ball bearing and slots
- guide au sol avec roulements a billes et fentes guida a pavimento con rodamientos y presillas

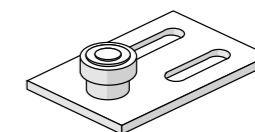

OMIPV00043

- guida a pavimento con ruota in plastica ed asole
- floor guide with plastic wheel and slots
- guide au sol avec roulette en plastique et fentes guida a pavimento con rodillo y presillas

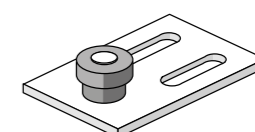

COM40202

- profilo a U 40 x 20 x 2 (da montare con CT16036 e CT16036B)
- U profile 40 x 20 x 2 (to be assembled with CT16036 e CT16036B)
- profil U 40 x 20 x 2 (a monter avec CT16036 e CT16036B)
- perfil U 40 x 20 x 2 (armar con CT16036 e CT16036B)

L = 6000 mm

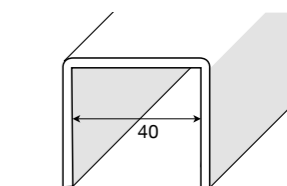

COM35202

- profilo per guida pavimento (da montare con OMIPV00043)
- floor guide profile (to be assembled with OMIPV00043)
- profil pour guide au sol (a monter avec OMIPV00043)
- perfil de regulacion al suelo (armar con OMIPV00043)

L = 6000 mm

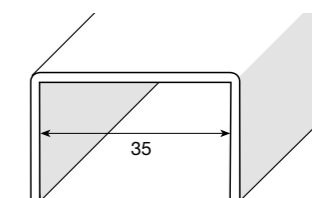

PORTE VA E VIENI

PUSH & PULL DOORS / PORTES VA-ET-VIEN / PUERTAS DE VAIVÉN

COLDTECH

SEL000035

- profilo in alluminio per porte non schiumate
- aluminium profile for doors not foam
- profil en aluminium pour portes pas injectée
- perfil de aluminio para puertas no inyectados

VA & VIENI L = 6500 mm

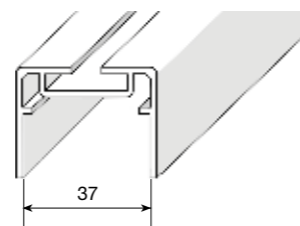

SEL000016

- bordo battente Va e Vieni schiumati
- door-leaf profile for To and Fro doors foamed
- profile bord vantail pour Va et Vien injectée
- perfil borde batiente Va e Vieni inyectados

L = 6000 mm

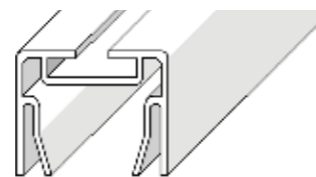

TMP000005

- profilo ad "H" (da montare con SEL000016)
- pvc "H" profile (to be assembled with SEL000016)
- profile "H" en pvc (a monter avec SEL000016)
- perfil "H" en pvc (armar con SEL000016)

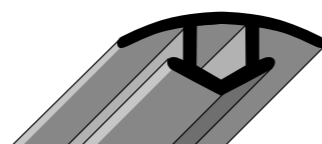

POL000010

- profilo altezza variabile
- profile variable height
- profil hauteur variable
- perfil de altura variable



DOC85600

- Oblò ovale 663 x 343 mm
- oval window 663 x 343 mm
- oval hublot 663 x 343 mm
- vantanilla 663 x 343 mm

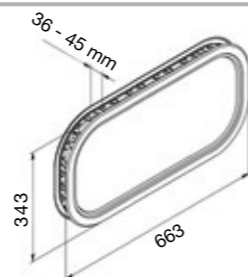

6904004000002

- oblò 30X45 senza guarnizione
- porthole 30X45 without gasket
- hublot 30X45 sans joint
- vantanilla 30X45 sin burlete

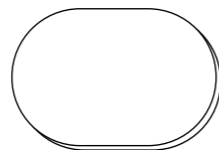

6904004000011

- oblò 30X45 con guarnizione
- porthole 30X45 with gasket
- hublot 30X45 avec joint
- vantanilla 30X45 con burlete

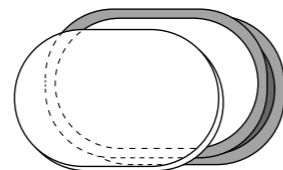

SELP000010 (H 150 mm)

SELP000400 (H 800 mm)

SELP000200 (H 1000 mm)

- paracolpi
- bumpers
- butoirs
- parachoques

L = 1000 mm



12

PORTE VA E VIENI

PUSH & PULL DOORS / PORTES VA-ET-VIEN / PUERTAS DE VAIVÉN

COLDTECH

OMIP000009

- cerniera PVC alta VA & VIENI con blocco a 90°
- PVC hinge high for push&pull door with 90° block
- charnière PVC haute pour VA-ET-VIEN avec blocage 90°
- bisagra PVC alta para VAIVÉN con bloqueo 90°

OMIP000016

- cerniera PVC bassa VA & VIENI con blocco a 90°
- PVC hinge low for push&pull door with 90° block
- charnière PVC faible pour VA-ET-VIEN avec blocage 90°
- bisagra PVC bajo para VAIVÉN con bloqueo 90°

OMIP000007

- cerniera PVC alta VA & VIENI senza blocco
- PVC hinge high for push&pull door without block
- charnière PVC haute pour VA-ET-VIEN sans blocage
- bisagra PVC alta VAIVÉN sin bloqueo

OMIP000017

- cerniera PVC bassa VA & VIENI senza blocco
- PVC hinge low for push&pull door without block
- charnière PVC faible pour VA-ET-VIEN sans blocage
- bisagra PVC bajo para VAIVÉN sin bloqueo

OMIP000022

- cerniera PVC alta VA & VIENI con blocco a 90°
- PVC hinge high for push&pull door with 90° block
- charnière PVC haute pour VA-ET-VIEN avec blocage 90°
- bisagra PVC alta para VAIVÉN con bloqueo 90°

OMIP000023

- cerniera PVC bassa VA & VIENI con blocco a 90°
- PVC hinge low for push&pull door with 90° block
- charnière PVC faible pour VA-ET-VIEN avec blocage 90°
- bisagra PVC bajo para VAIVÉN con bloqueo 90°

OMIP000021

- cerniera PVC alta VA & VIENI senza blocco
- PVC hinge high for push&pull door without block
- charnière PVC haute pour VA-ET-VIEN sans blocage
- bisagra PVC alta VAIVÉN sin bloqueo

OMIP000024

- cerniera PVC bassa VA & VIENI senza blocco
- PVC hinge low for push&pull door without block
- charnière PVC faible pour VA-ET-VIEN sans blocage
- bisagra PVC bajo para VAIVÉN sin bloqueo

TORM000001

- viti per cerniera VA & VIENI L = 38
- screws hinge PUSH & PULL L = 38
- vis pour charnière VA - ET - VIEN L = 38
- tornillos para bisagra VAIVÉN L = 38

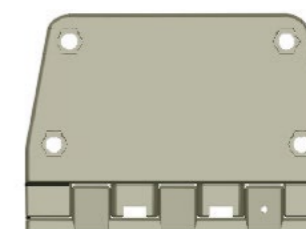
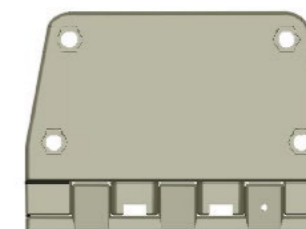

13

PORTE VA E VIENI

PUSH & PULL DOORS / PORTES VA-ET-VIEN / PUERTAS DE VAIVÉN

COLDTECH

OMIP000030

- cerniera completa di tirante e viti di collegamento con o senza blocco 90°
- *hinge with tie rod and screws with-without 90° bloc*
- charniere avec tirant et vis avec ou sans blocage a 90°
- *bisagra con tirante y tornillos con o sin bloque a 90°*



OMIP000031

- cerniera completa di tirante e viti di collegamento con piastra in plastica con o senza blocco 90°
- *hinge with tie rod and screws with plastic plate with-without 90° bloc*
- charniere avec tirant et vis avec plaque en plastique avec ou sans blocage a 90°
- *bisagra con tirante y tornillos con placa de plastico con o sin bloque a 90°*



6909005000052

- pinna H = 32,00 mm coestrusa
- *coextruded fin H = 32,00 mm*
- aileron H = 32,00 mm coextrudé
- *aleta H = 32,00 mm coextrusionada*

L = 2 m - 2,5 m



6909005000053

- pinna H = 40,00 mm coestrusa
- *coextruded fin H = 40,00 mm*
- aileron H = 40,00 mm coextrudé
- *aleta H = 40,00 mm coextrusionada*

L = 2 m - 2,5 m



6909005000054

- guarnizione per obló in lexan battente spessore 40 mm
- *lexan porthole gasket for 40 mm door blade thick*
- joint pour hublot en lexan vantail ep. 40 mm
- *guarnicion ventanilla en lexan para batiente esp. 40 mm*

L = 25 m (rotolo)



CT11031

- per obló in lexan battente spessore 15 mm
- *lexan porthole gasket for 15 mm door blade thick*
- joint pour hublot en lexan vantail ep. 15 mm
- *guarnicion ventanilla en lexan para batiente esp. 15 mm*



14

ATMOSFERA CONTROLLATA

CONTROLLED ATMOSPHERE / ATMOSPHERE CONTRÔLÉ / ATMÓSFERA CONTROLADA ...

COLDTECH

ARC0000009

- sportello con telaio per ATC
- *glass view window with frame for ATC*
- hublot en verre avec cadre pour l'ATC
- *ventana de cristal con marco de ATC*

ATC L = 6500 mm



ARC0000011

- Gancio eccentrico per ATC
- *Eccentric hook for ATC*
- crochet excentrique pour l'ATC
- *Gancho excéntrico para el ATC*



ARC0000015

- staffa rinforzo ganci laterali per eccentrici
- *bracket reinforcement side hooks for eccentric*
- crochet latéraux de renforcement du support pour excentriques
- *ganchos laterales de refuerzo de corchete para excéntricos*

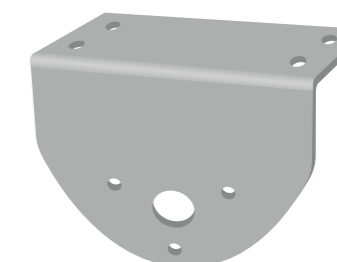

ARC0000016

-
- *internal buffer reinforcement for eccentric*
- renfort tampon interne pour excentrique
- *refuerzo interno para excéntricos*



15

6909005000015

- guarnizione perimetrale per ATC
- *perimetric gasket for ATC*
- joint périphérique pour ATC
- *sello de perímetro para ATC*

L = 25 m (rotolo)



6909005000060

- guarnizione inferiore per ATC
- *bottom gasket for ATC*
- joint de fond pour ATC
- *sello inferior para ATC*

L = 50 m (rotolo)



MAC0000300

- mousse adesiva per AC
- *foam gasket for CA*
- bourrelet mousse pour AC
- *empaque espuma para AC*

L = 25 m (rotolo)

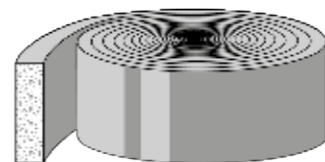

SEL000011

- bordo battente 68,00 mm schiumata
- *door leaf profile edge 68,00 mm foamed*
- bord battant 68,00 mm injectée
- *borde batiente 68,00 mm inyectados*

• TN65 L = 6000 mm

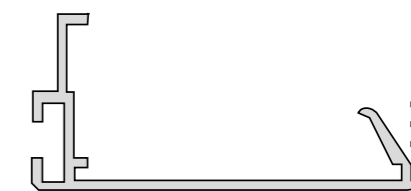

SEL000012

- bordo battente 92,00 mm schiumata
- *door leaf profile edge 92,00 mm foamed*
- bord battant 92,00 mm injectée
- *borde batiente 92,00 mm inyectados*

• TN95 - BT95 L = 6000 mm

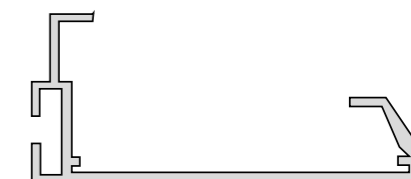

SEL000013

- bordo battente 120,00 mm schiumata
- *door leaf profile edge 120,00 mm foamed*
- bord battant 120,00 mm injectée
- *borde batiente 120,00 mm inyectados*

• BT120 L = 6000 mm



6901021000016

- bordo battente 140,00 mm schiumato
- *door leaf profile edge 140,00 mm foamed*
- bord battant 140,00 mm injectée
- *borde batiente 140,00 mm inyectados*

• BT140 L = 6500 mm



SEL000023

- supporto lamiera ad H
- *H bracket*
- support toles en H
- *suporte de chapa en H*

L = 6000 mm

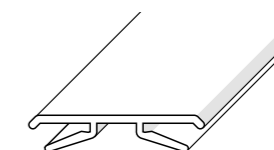

VIB11751

- supporto lamiera T
- *T bracket*
- support tôles en T
- *soporte de chapa en T*

L = 6000 mm

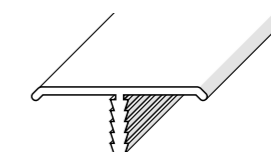

6901021000004

- copri supporto resistenza
- heating support covering profile
- profil couvre support cordon chauffant
- perfil cubre soporte resistencia

L = 6500 mm

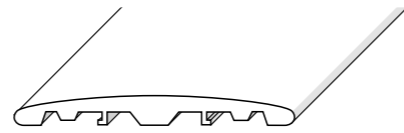

6901021000011

- supporto resistenza
- heating-element support
- support pour cordon chauffant
- soporte resistencia

L = 6500 mm

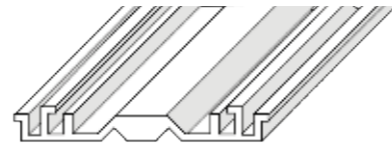

SELO00009

- profilo battente da 69,5 mm non schiumato
- door leaf profile 69,5 mm not foamed
- profil bord vantail 69,5 mm ne pas injectée
- perfil borde batiente 69,5 mm no inyectados

L = 6400 mm

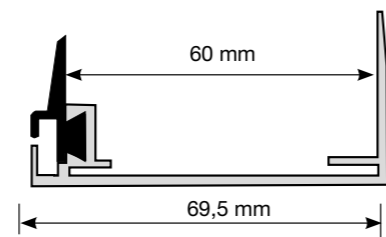

SELO00010

- profilo battente da 89 mm non schiumato
- door leaf profile 89 mm not foamed
- profil bord vantail 89 mm ne pas injectée
- perfil borde batiente 89 mm no inyectados

L = 6000 mm

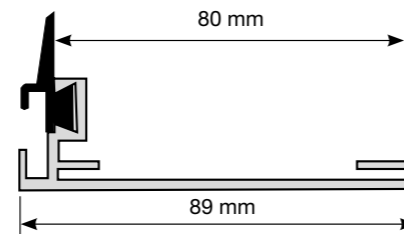

VIB0000010

- profilo battente da 109,5 mm non schiumato
- door leaf profile 109,5 mm not foamed
- profil bord vantail 109,5 mm ne pas injectée
- perfil borde batiente 109,5 mm no inyectados

L = 6000 mm

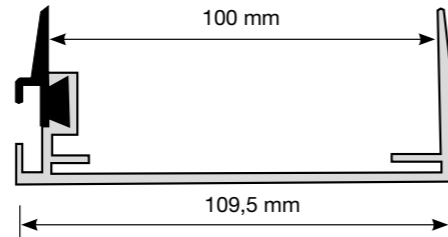

VIB00001

- profilo battente da 129,5 mm non schiumato
- door leaf profile 129,5 mm not foamed
- profil bord vantail 129,5 mm ne pas injectée
- perfil borde batiente 129,5 mm no inyectados

L = 6000 mm

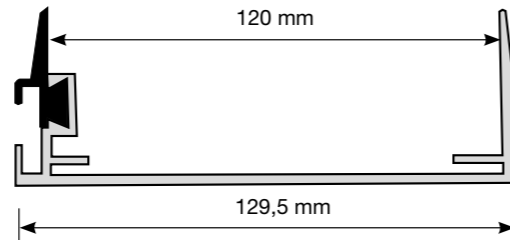

TMP000001

- profilo in pvc, per interruzione ponte termico, profilo battente da 69,5 / 89 mm
- profile in pvc, for thermal bridge interruption, door leaf profile 69,5 / 89 mm
- profil en pvc, pour interruption pont thermique, profil bord vantail 69,5 / 89 mm
- perfil in pvc, para nterruption puente termico, perfil borde batiente 69,5 / 89 mm

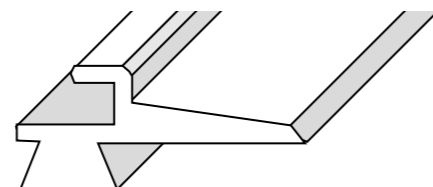

SELO00015

- profilo alluminio per telaio
- profile alu for frame
- bati aluminium pour châssis
- perfil aluminio al marco

L = 6000 mm

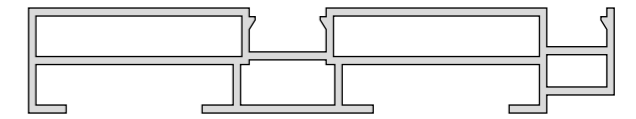

SELO00024

- copertura alluminio per passaggio resistenza
- cover for heater passage
- couvertur pour passage resistance
- cobertura para passje resistencia

L = 6000 mm

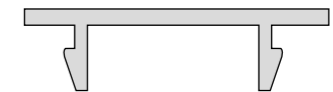

PVC000500

- profilo pvc rigido per interruzione ponte termico su telaio di alluminio
- pvc profile for thermal bridge interruption on frame alu profile
- pvc profil pou interruption pont thermique poru hiusserie alu
- perfil para nterruption puente termico marco in aluminio
- L = 2000 mm

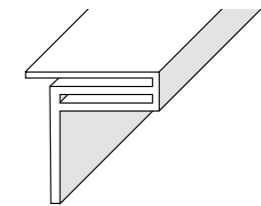

VIB0000013

- profilo perimetrale per battenti da 100 mm non schiumato
- door leaf perimetral profile 100 mm not foamed
- Profil perimetral pour vantaux 100 mm ne pas injectée
- perfil perimetral para batiente 100 mm no inyectados

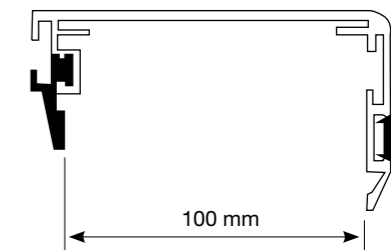

IMA0000001

- telaio "L" 130,00 x 60,00 mm
- 130,00 x 60,00 mm "L" frame
- chassis "L" 130,00 x 60,00 mm
- marco "L" 130,00 x 60,00 mm

L = 5800 mm

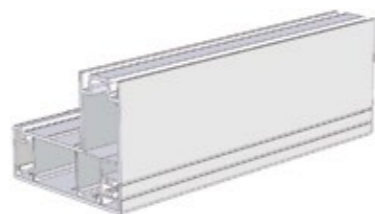

IMA0000002

- spessore telaio 20,00 mm
- frame thickness 20,00 mm
- épaisseur chassis 20,00 mm
- espesor marco 20,00 mm

L = 5800 mm

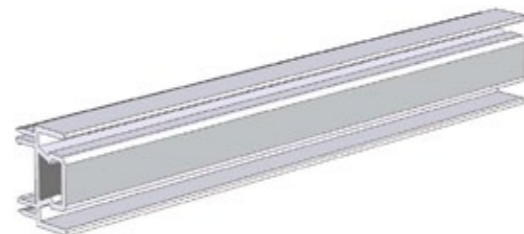

IMA0000004

- spessore telaio 40,00 mm
- frame thickness 40,00 mm
- épaisseur chassis 40,00 mm
- espesor marco 40,00 mm

L = 5800 mm

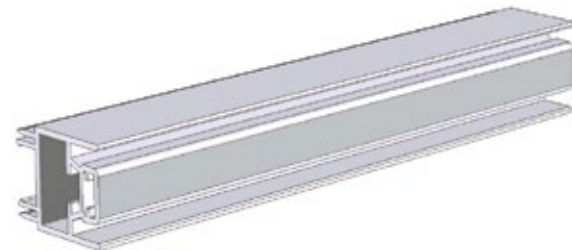

IMA0000010

- spessore telaio 100,00 mm
- frame thickness 100,00 mm
- épaisseur chassis 100,00 mm
- espesor marco 100,00 mm

L = 5800 mm

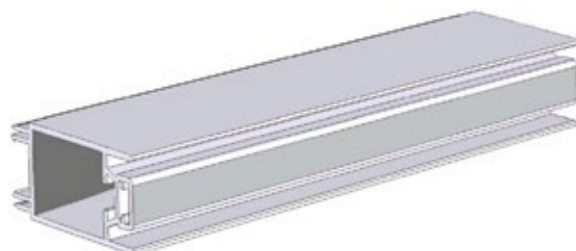

FRA140+PVC

- Telaio pvc 140 mm + copertura vano ponte termico in pvc
- pvc frame profile 140 mm + pvc cover profile
- chassis 140 mm + couverture résistance en pvc
- marco pvc 140 mm + tapa marco en pvc para resistencia

L = 5800 mm

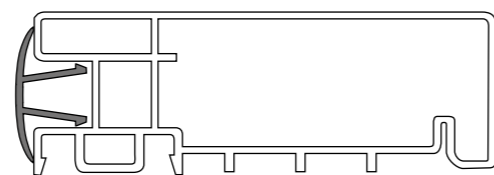

IMA0000200

- profilo in PVC bordo battente semincassato sp. = 68
- semirecessed PVC blade edge profile thk. = 68
- perfil PVC borde batiente semincassato esp. = 68
- profil PVC bord vantail demi-encassé épais = 68

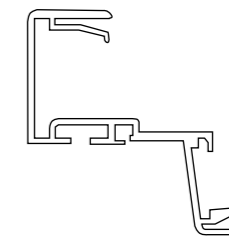

IMA0000050

- telaio PVC per profilo in PVC bordo battente semincassato sp. = 68
- frame PVC for semirecessed PVC blade edge profile thk. = 68
- chassis PVC pour profil PVC borde batiente semincassato esp. = 68
- marco PVC para perfil PVC bord vantail demi-encassé épais = 68

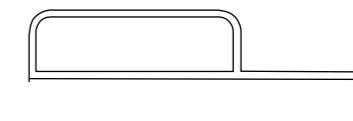

6903021000030

- supporto guarnizione perimetrale porte inox
- perimetric seal support for stainless steel doors
- support joint périphérique portes inox
- soporte burlete perimetral puertas inox

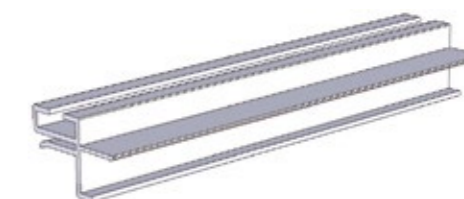

IMA0000041 (RAL 9010)

- telaio PVC 110 mm
- PVC Frame 110 mm
- chassis PVC 110 mm
- marco PVC 110 mm

L = 6000 mm

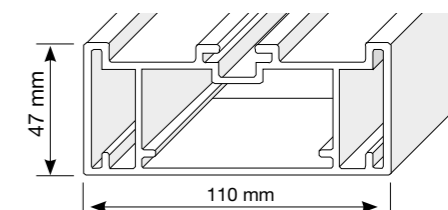

IMA0000040 (RAL 9010)

- telaio PVC 130 mm
- PVC Frame 130mm
- chassis PVC 130 mm
- marco PVC 130mm

L = 5800 mm

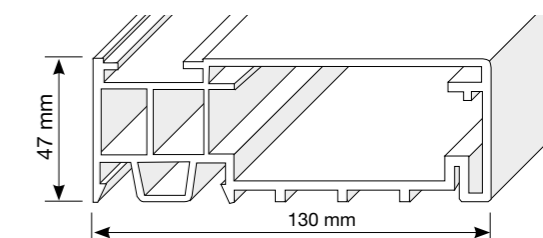

VIB0000012

- copertura copriresistenza in alluminio per telaio
- heating wire cover aluminium profile
- couverture câble chauffant en aluminium
- tapa marco en aluminio para resistencia

L = 5800 mm

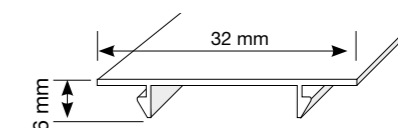

IMA0000045 (RAL 9010)

- tappo telaio copriresistenza
- heating wire covering pvc profile
- couverture câble chauffant en pvc
- Tapa marco en pvc para resistencia

L = 5800 mm

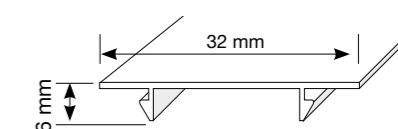

IMA0000140

- telaio 140 mm
- frame 140 mm
- chassis 140 mm
- marco 140 mm

L = 5800 mm

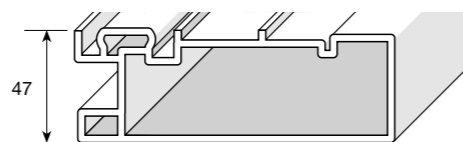

IMA0000100 (RAL 9010)

- controtelaio PVC 80 mm
- PVC Counterframe 80 mm
- contrecadre PVC 80 mm
- contromarco PVC 80 mm

L = 5800 mm

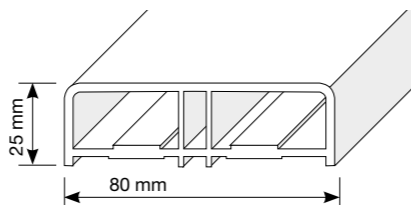

IMA0000101 (RAL 9010)

- controtelaio PVC 130 mm
- PVC Counterframe 130 mm
- contrecadre PVC 130 mm
- Contromarco PVC 130mm

L = 5800 mm

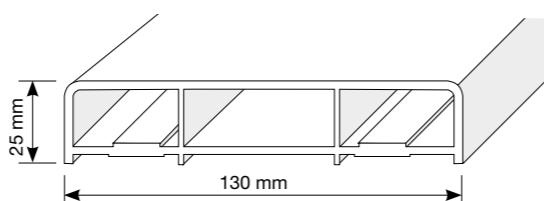

TMP000002

- profilo per collegamento del controtelaio al telaio
- pvc profile for of counter frame connection to the frame
- profil pour assemblage du contre cadre en pvc à la huisserie
- perfil para conexion del contromarco en pvc al marco

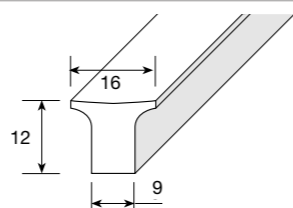

TMP000013

- profilo per collegamento del controtelaio al telaio
- pvc profile for of counter frame connection to the frame
- profil pour assemblage du contre cadre en PVC à la huisserie
- perfil para conexion del contomarco en PVC al marco

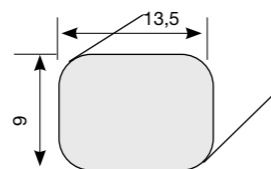

TMP000008

- piattina 15x4 sostegno guarnizione inferiore
- PVC gasket support 15X4 support floor gasket
- support joint en PVC 15X4 support balaie racleur
- soporte burlete en PVC 15X4 soporte empaque piso

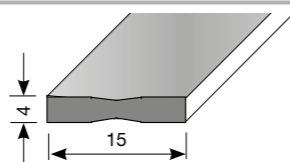

TMP000009

- profilo sostegno doppia guarnizione
- PVC door double gasket support
- profil support double joint en PVC
- perfil para doble burlete en PVC

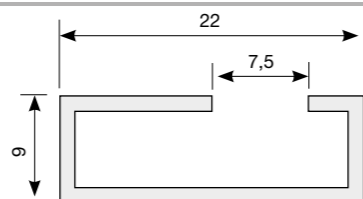

TMP000012

- profilo in PVC supporto guarnizione aggiuntiva grigio
- additional gasket support PVC profile grey
- perfil PVC soporte burlete adiconas gris à la huissetieris
- perfil PVC soutien joint supplémentaire gris

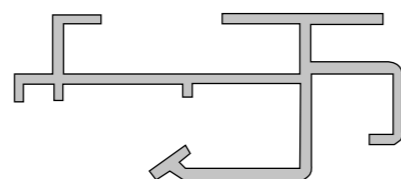

ISE000005

- guarnizione perimetrale coestrusa
- coextruded perimetric gasket
- joint périphérique coextrudée
- burlete perimetral coextrusionado

• TN65

L = 50 m (rotolo)



ISE000009

- guarnizione perimetrale coestrusa base larga
- coextruded perimetric gasket wide strip
- joint périphérique coextrudée base large
- burlete perimetral coextrusionado base grande

• TN95

L = 25 m (rotolo)



ISE0000010

- Guarnizione perimetrale - Aletta piccola
- Perimetric gasket - Narrow base
- Joint périphérique - Base étroite
- Burlete perimetral - Base pequena

• TN95

L = 2500 mm (rotolo)

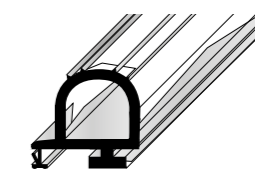

ISE00002CT

- guarnizione perimetrale con passaggio resistenza base larga
- perimetric gasket with resistance passage wide strip
- joint périphérique avec résistance passage base large
- burlete perimetral con paso resistencia base grande

• BT95 - BT120 - BT140

L = 25 m (rotolo)



ISE000014

- Guarnizione perimetrale con passaggio resistenza - INRE
- Perimetric gasket with heating cable passage - INRE
- Joint périphérique avec passage résistance - INRE
- Burlete perimetral con paso resistencia - INRE

• BT95 - BT120 - BT140

L = 25 m (rotolo)

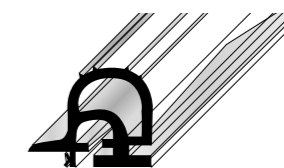

ISE000002

- guarnizione perimetrale con passaggio resistenza aletta piccola
- perimetric gasket with heater passage narrow strip
- joint périphérique avec passage résistance base étroite
- burlete perimetral con paso resistencia base pequena

• BT95 - BT120 - BT140

L = 25 m (rotolo)

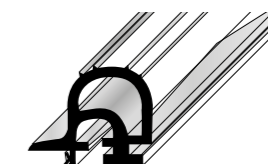

ISE000008

- guarnizione inferiore
- lower gasket
- joint inférieur
- burlete inferior

• TN65

L = 40 m (rotolo)

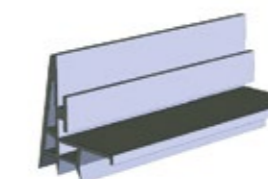

ISE000001

- Guarnizione inferiore - Aletta piccola
- *Lower gasket - Narrow base*
- Joint inférieur - Base étroite
- *Burlete inferior - Base pequena*

• **TN95** L = 30 m (rotolo)

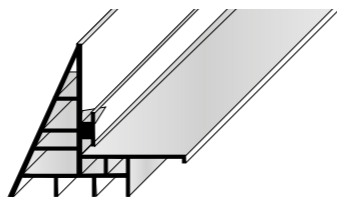

ISE000007

- guarnizione inferiore base larga
- *lower gasket wide strip*
- joint inférieur base large
- *burlete inferior base grande*

• **TN95** L = 30 m (rotolo)



ISE000011

- guarnizione inferiore con passaggio resistenza
- *lower gasket with heating cable passage*
- joint inférieur avec résistance passage
- *burlete inferior puerta con paso resistencia*

• **BT95 - BT120 - BT140** L = 25 m (rotolo)

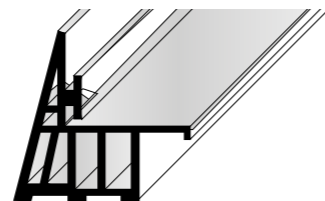

ISE000012

- guarnizione inferiore
- *lower gasket*
- joint inférieur
- *burlete inferior*

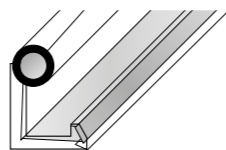

ISE000013

- guarnizione inferiore perimetrale
- *lower gasket perimetral*
- joint inférieur périmétral
- *burlete inferior perimetral*

L = 25 m (rotolo)

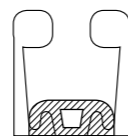

TMP000010

- profilo fissazione per guarnizione ISE000013
- *fixing strip for gasket ISE000013*
- *faidisseur pour joint ISE000013*
- *Perfil soporte burlete ISE000013*

• **TN95** L = 2500 mm

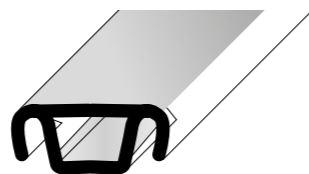

6909005000001

- rivestimento lamiera "U" per ponte termico
- *U-shaped sheet-metal covering for heat bridge*
- *revetement tole "U" pour pont thermique*
- *revestimiento chapa "U" para puente térmico*

• **BT95 - BT120 - BT140** L = 100 m (rotolo)

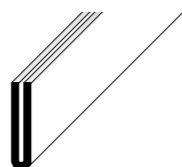

ISE000006

- perimetrale a fissaggio
- *eaf-door perimetral gasket*
- joint d'étancheite périmétral vantail
- *junta perimetral para batiente*

L = 50 m (rotolo)

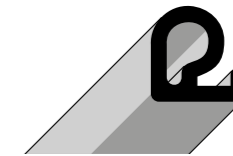

6909005000027

- per interruzione ponte termico lamiera battente
- *thermal bridge interruption blade steel sheet*
- *brise pont thermique tole vantail*
- *interrupcion puente termico chapa oja*

L = 25 m (rotolo)

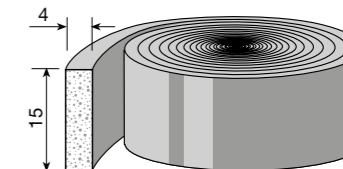

OMIPMO001

- maniglia esterna orizzontale con serratura
- external horizontal handle with key
- poignée externe horizontale avec clé
- cierre externa horizontal con llave



OMIPME0100

- maniglia esterna senza serratura
- external handle without lock
- poignée externe sans serrure
- cierre externa sin llave



OMIPME0001

- maniglia esterna con serratura
- external handle with lock
- poignée externe avec clé
- cierre externa con llave



OMIPMV0001

- maniglia esterna verticale con serratura Edizione 2020
- external vertical handle with key 2020 Edition
- poignée externe vertical avec clé 2020 Édition
- manilla externa vertical con llave Edición 2020



OMIPMV0100

- maniglia esterna verticale senza serratura Edizione 2020
- external vertical handle without key 2020 Edition
- poignée externe vertical sans clé 2020 Édition
- manilla externa vertical sin llave Edición 2020



OMIPMI0001

- maniglia interna di emergenza
- emergency door inside handle
- poignée interne pour porte de secours
- cierre interno puerta de emergencia



OMIPMC0001

- tirante (battente 60)
- tie rod (door leaf 60)
- tirant (vantail 60)
- tirante (batiente 60)

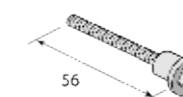

OMIPMC0002

- tirante (battente 68)
- tie rod (door - leaf 68)
- tirant (vantail 68)
- tirante (batiente 68)

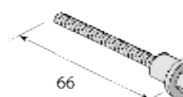

OMIPMC0003

- tirante (battente 80) nero/grigio
- tie rod (door - leaf 80) black/grey
- tirant (vantail 80) - noir/gris
- tirante (batiente 80) - nero/gris

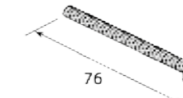

OMIPMC0004

- tirante (battente 92)
- tie rod (door - leaf 92)
- tirant (vantail 92)
- tirante (batiente 92)

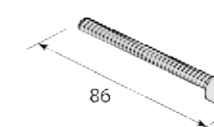

OMIPMC0005

- tirante (battente 100)
- tie rod (door leaf 100)
- tirant (vantail 100)
- tirante (batiente 100)

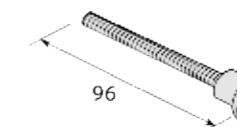

OMIPMC0006

- tirante (battente 120)
- tie rod (door - leaf 120)
- tirant (vantail 120)
- tirante (batiente 120)

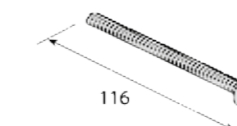

OMIPMC0007

- tirante universale
- tie rod universal
- tirant universel
- tirante universales

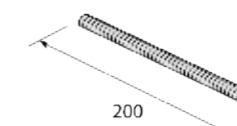

OMIPMC0010

- asta di trasmissione (battente 60)
- drive staff (door - leaf 60)
- tige de transmission (vantail 60)
- barra de transmision (batiente 60)

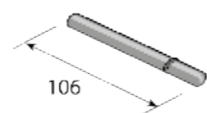

OMIPMC0011

- asta di trasmissione (battente 68)
- drive staff (door - leaf 68)
- tige de transmission (vantail 68)
- barra de transmision (batiente 68)

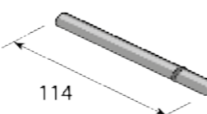

OMIPMC0012

- asta di trasmissione (battente 80)
- drive staff (door leaf 80)
- tige de transmission (vantail 80)
- barra de transmision (batiente 80)

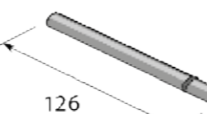

OMIPMC0013

- asta di trasmissione (battente 92)
- drive staff (door leaf 92)
- tige de transmission (vantail 92)
- barra de transmision (batiente 92)



OMIPMC0014

- asta di trasmissione (battente 100)
- drive staff (door - leaf 100)
- tige de transmission (vantail 100)
- barra de transmision (batiente 100)



OMIPMC0015

- asta di trasmissione (battente 120)
- drive staff (door - leaf 120)
- tige de transmission (vantail 120)
- barra de transmision (batiente 120)

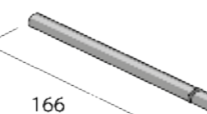

OMIPMC0016

- asta di trasmissione universale
- drive staff universal
- tige de transmission universel
- barra de transmision universales

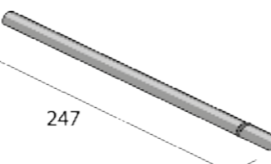

CT13071

- canotto (battente 60)
- tube (doors - leaf 60)
- tuyau (vantail 60)
- tubo (batiente 60)

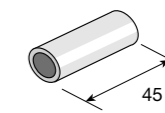

CT13072

- canotto (battente 68)
- tube (doors - leaf 68)
- tuyau (vantail 68)
- tubo (batiente 68)

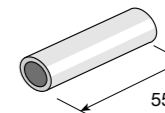

CT13073

- canotto (battente 80)
- tube (doors - leaf 80)
- tuyau (vantail 80)
- tubo (batiente 80)

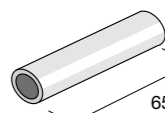

CT13073

- canotto (battente 92)
- tube (doors - leaf 92)
- tuyau (vantail 92)
- tubo (batiente 92)

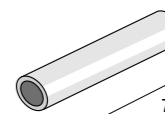

CT13074

- canotto (battente 100)
- tube (doors - leaf 100)
- tuyau (vantail 100)
- tubo (batiente 100)

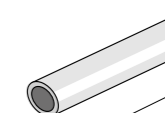

CT13075

- canotto (battente 120)
- tube (doors - leaf 120)
- tuyau (vantail 120)
- tubo (batiente 120)



CT13076

- Canotto universale
- tube universal
- tuyau universel
- Tubo universales



MANIGLIE

HANDLES / POIGNÉES / MANIJAS

COLDTECH

OMIPMC0020

- riscontro registrabile
- *adjustable striker*
- repère réglable
- *elemento de contacto regulable*

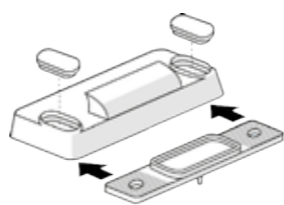

OMIPMC0026

- riscontro registrabile piccolo
- *adjustable striker small*
- petite repère réglable
- *elemento de contacto regulable pequeño*

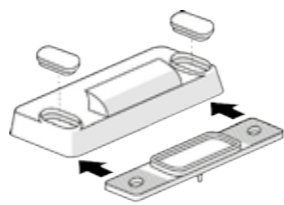

OMIP000050

- kit maniglia esterna + Interna + tiranteria con serratura
- *kit ext + int handle + accessories with key*
- Kit poignée ext + int + accessoires avec clé
- *Kit cierre ext + int + accesorios con llave*



OMIP000049

- kit senza chiave
- *kit without key*
- Kit sans clé

Kit sin llave

JUR0000001

- kit maniglia esterna + Interna + tiranteria con serratura
- *kit ext + int handle + accessories with key*
- Kit poignée ext + int + accessoires avec clé
- *Kit cierre ext + int + accesorios con llave*



JUR0000003

- kit senza chiave
- *kit without key*
- Kit sans clé
- *Kit sin llave*

OMIP002020

- Kit maniglia esterna verticale con serratura + interna + accessori Edizione 2020
- *Kit external vertical handle with lock + internal + accessories 2020 Edition*
- Kit poignée externe vertical avec clé + interne + accessoires 2020 Édition
- *Kit manilla externa vertical con llave + cierre interior + accesorios Edición 2020*



OMIP002020SC

- Kit maniglia esterna verticale senza serratura + interna + accessori Edizione 2020
- *Kit external vertical handle without lock + internal + accessories 2020 Edition*
- Kit poignée externe vertical sans clé + interne + accessoires 2020 Édition
- *Kit manilla externa vertical sin llave + cierre interior+accesorios Edición 2020*

30

MANIGLIE PER PORTE SCORREVOLI

HANDLES FOR SLIDING DOORS / MANCHES POUR PORTES COULISSANTES / TIRADORES PARA PUERTAS CORREDERAS

COLDTECH

OMIPSS00004

- serratura porte scorrevoli
- *lock for sliding doors*
- fermeture pour portes coulissantes
- *cierre para puertas corredizas*

L = 61 mm



OMIPSS00008

- serratura porte scorrevoli
- *lock for sliding doors*
- fermeture pour portes coulissantes
- *cierre para puertas corredizas*

L = 125 mm



OMIPSS00006

- serratura porte scorrevoli
- *lock for sliding doors*
- fermeture pour portes coulissantes
- *cierre para puertas corredizas*

L = 140 mm



OMIPSS00010

- serratura porte scorrevoli
- *lock for sliding doors*
- fermeture pour portes coulissantes
- *cierre para puertas corredizas*

L = 96 mm



OMIPSS00000

- serratura porte scorrevoli
- *lock for sliding doors*
- fermeture pour portes coulissantes
- *cierre para puertas corredizas*

L = 69 mm



OMIPV000015

- maniglia interna fissa a vaschetta
- *internal fixed recessed handle*
- poignée interne fixe barquette
- *manilla interna fija empotrada*



6909003000063

- maniglia interna a leva reversibile
- *internal reversible lever handle*
- poignée interne a levier réversible
- *manilla interna de palanca reversible*

**• TN95 - BT95 - BT120 - BT140
max. 120,00 Kg**



31

MANIGLIE PER PORTE SCORREVOLI

HANDLES FOR SLIDING DOORS / MANCHES POUR PORTES COULISSANTES / TIRADORES PARA PUERTAS CORREDERAS

COLDTECH

6909003000087

- maniglia interna a leva reversibile
- *internal reversible lever handle*
- poignée interne a levier réversible
- *manilla interna de palanca reversible*

• TN95 - BT95 - BT120 - BT140 over 120,00 Kg



OMIP000060

- maniglia esterna fissa laterale
- *fixed external side handle*
- poignée externe fixe laterale
- *manilla externa fija lateral*

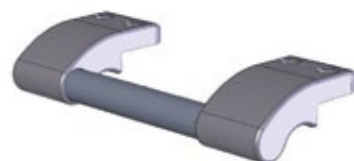

OMIP000061

- maniglia esterna fissa laterale tubo inox
- *fixed external side handle tube in stainless steel*
- poignée externe fixe laterale tube en acier inoxydable
- *manilla externa fija lateral tubo en acero inoxidable*



6909003000090

- maniglia esterna fissa frontale
- *fixed external front handle*
- poignée externe fixe frontale
- *Manilla externa fija frontal*



Ombe0000001

- maniglia esterna
- *external handle*
- poignée externe
- *maneta externa*

• BT140

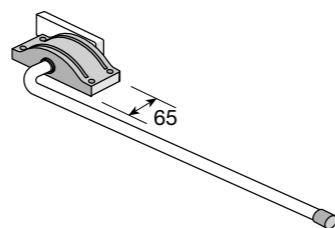

IK8100

- maniglia a leva int. + ext. universale
- *level handle int. + ext.*
- poignée int. + ext. a levier
- *maneta int. + ext. de palanca*



32

ACCESSORI PLASTICA PER PORTE SCORREVOLI

PLASTIC ACCESSORIES FOR SLIDING DOORS / ACCESSOIRES PLASTIQUE PORTES COULISSANTES / ACCESORIOS DE PLÁSTICO PUERTAS CORREDERAS

COLDTECH

OMIP000004 (dx)

OMIP000005 (sx)

- carrucola completa dx/sx in plastica con perno da 160 o180 mm
- *complete rh/lt-hand plastic sheave with pin from 160 or180 mm*
- poulie complète droite/gauche en plastique avec la broche de 160 ou180 mm
- *polea completa dcha/izqda en plástico con el pasador de 160 ou180 mm*



CT14043

- carrucola in acciaio taglio laser verniciato a polvere
- *pulley in powder-coated laser welded*
- poulie en acier soudure laser avec revêtement en poudre
- *polea in acero soldado laser barnizado de polvo*

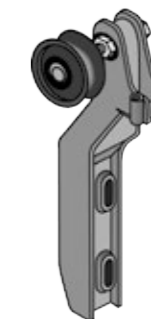

CT14044

- carrucola in acciaio taglio laser verniciato a polvere
- *pulley in powder-coated laser welded*
- poulie en acier soudure laser avec revêtement en poudre
- *polea in acero soldado laser barnizado de polvo*

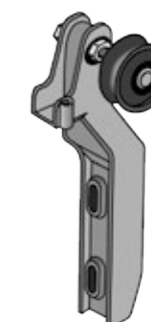

OMIPP00012

- supporto in plastica
- *plastic support*
- support en plastique
- *soporte en plastica*

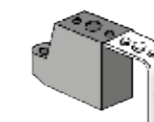

OMIPP000006

- ruota in PVC per carrucola Ø90,00 mm
- *PVC sheave wheel Ø90,00 mm*
- roue en PVC pour poulie Ø90,00 mm
- *rueda en PVC para polea Ø90,00 mm*



33

ACCESSORI PLASTICA PER PORTE SCORREVOLI

PLASTIC ACCESSORIES FOR SLIDING DOORS/ ACCESSOIRES PLASTIQUE PORTES COULISSANTES / ACCESORIOS DE PLÁSTICO PUERTAS CORREDERAS

COLDTECH

6909004000005 (dx)

6909004000010 (sx)

- carrucola per porte con guidovia dx/sx
- door sheave right/left-hand guidetrack
- poulie pour portes avec railguide droite/gauche
- polea para puertas con soporte guía dcho/izqdo



6909004000068

- carrucola per porte 2 ante reversibile
- reversible sheave for 2-leaf door
- poulie pour porte 2 volete réversible
- polea para puerta 2 hojas reversible



OMIPV00004

- riscontro per gancio di chiusura inferiore
- striker for lower latch hook
- correspondance pour crochet fermeture inférieur
- anclaje para gancho de cierre inferior



6909010000155

- gancio di chiusura inferiore
- lower latch hook
- crochet de fermeture inférieur
- gancho de cierre inferior



OMIPV00003

- gancio di chiusura inferiore
- lower latch hook
- crochet de fermeture inférieur
- gancho de cierre inferior



69090010000059 modTN65

- registro piccolo per guida inferiore reversibile
- small reversible adjuster for lower guide
- petit registre pour guide inférieur réversible
- registro pequeño para guía inferior reversible



69090010000097 modTN90

- registro grande per guida inferiore reversibile per porte simmetriche (da montare con SEL000002)
- reversible rear register big for lower guide symmetric door (to be assembled with SEL000002)
- registre grand pour guide inférieur réversible symétric portes (a monter avec SEL000002)
- registro grande en el riel inferior puertas simétricas reversibles (armar con SEL000002)



ACCESSORI PLASTICA PER PORTE SCORREVOLI

PLASTIC ACCESSORIES FOR SLIDING DOORS/ ACCESSOIRES PLASTIQUE PORTES COULISSANTES / ACCESORIOS DE PLÁSTICO PUERTAS CORREDERAS

COLDTECH

69090010000060 modTN90-120

- registro grande per guida inferiore reversibile per battenti asimmetrici
- large reversible adjuster for lower guide asymmetric wings
- grand registre pour guide inférieur réversible vantaux asymmetric
- registro grande para guía inferior reversible ojas asymmetricas



OMIPV00020 modTN90-120

- registro per guida inferiore reversibile per porte simmetriche
- reversible rear register for lower guide for symmetric doors
- registre pour guide inférieur réversible pour portes symétriques
- registro guía inferior reversible para puertas simetryricas



6909010000159 (dx)

6909010000160 (sx)

- staffa per guida inferiore dx/sx (da montare con SEL000002)
- rh/lh rear guide bracket (to be assembled with SEL000002)
- bride pour guide inférieur droit/gauche (a monter avec SEL000002)
- brida guía posterior derecha./izquierda (armar con SEL000002)



OMIPV00034 (dx)

OMIPV00035 (sx)

- staffa per guida inferiore dx/sx (da montare con SEL000029)
- rh/lh rear guide bracket (to be assembled with SEL000029)
- bride pour guide inférieur droit/gauche (a monter avec SEL000029)
- Brida guía posterior derecha/izquierda (armar con SEL000029)



6909010000162 (dx)

6909010000163 (sx)

- tappo per guida inferiore dx / sx (da montare con SEL000002)
- *rh/lh rear guide plug (to be assembled with SEL000002)*
- bouchon pour guide inférieur droit/gauche (a monter avec SEL000002)
- *tapeta guía posterior derecha/izquierda (armar con SEL000002)*

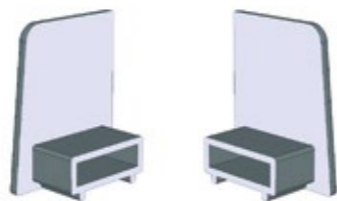

OMIPV00005

- tappo per guida inferiore reversibile (da montare con SEL000029)
- *rear guide plug reversible (to be assembled with SEL000029)*
- bouchon pour guide inférieur réversible (a monter avec SEL000029)
- *tapeta guía posterior (armar con SEL000029)*



OMIPV00030 (dx)

OMIPV00031 (sx)

- rampa binario con incavo dx/sx
- *right/left-hand rail ramp with cavity*
- rampe rail avec cavité droite/gauche
- *rampa vía con muesca dcha./izqda.*



OMIPV00032 (dx)

OMIPV00033 (sx)

- rampa binario senza incavo dx/sx
- *right/left-hand rail ramp without cavity*
- rampe rail sans cavité droite/gauche
- *rampa vía sin muesca dcha./izqda.*



6909010000167 (dx)

6909010000168 (sx)

- testata per guida superiore dx/sx
- *right/left-hand header for upper guide*
- tête pour guide supérieure droite/gauche
- *cabezal para guía superior dcha./izqda.*



6909010000173

- fermo corsa di apertura reversibile
- *reversible door opening stop*
- arret course a ouverture réversible
- *tope de apertura reversible*



6909010000148 RAL 9010

- cuneo in NYLON H = 16,00 mm
- *NYLON wedge H = 16,00 mm*
- cale en NYLON H = 16,00 mm
- *cuña en NYLON H = 16,00 mm*

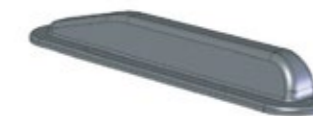

6909010000149 RAL 9010

- cuneo in NYLON H = 22,00 mm
- *NYLON wedge H = 22,00 mm*
- cale en NYLON H = 22,00 mm
- *cuña en NYLON H = 22,00 mm*

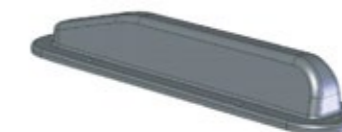

6909010000170

- coppia supporti per maniglia frontale
- *couple of support for front handle*
- paire supports pour poignée frontale
- *pareva soportes para manilla frontal*



OMIPV00042

- coppia supporti per maniglia laterale
- *couple of support for side handle*
- paire supports pour poignée latérale
- *pareva soportes para manilla lateral*



6909010000154

- riscontro per maniglia esterna
- *striker for external handle*
- correspondance pour poignée externe
- *anclaje para manilla externa*



OMIPV00018

- riscontro maniglia esterna
- *external handle striker*
- contre plaque poignée externe
- *apoyo maneta extern*



6909010000059

- tirante in PVC M12 x 160,00 mm
- PVC stay M12 x 160,00 mm
- tirant en PVC M12 x 160,00 mm
- espárrago de PVC M12 x 160,00 mm



6909010000060

- tirante in PVC M12 x 230,00 mm
- PVC stay M12 x 230,00 mm
- tirant en PVC M12 x 230,00 mm
- espárrago de PVC M12 x 230,00 mm



6909010000061

- tirante in PVC M12 x 300,00 mm
- PVC stay M12 x 300,00 mm
- tirant en PVC M12 x 300,00 mm
- espárrago de PVC M12 x 300,00 mm



6909010000062

- tirante in PVC M12 x 500,00 mm senza testa
- PVC stay M12 x 500,00 mm without head
- tirant en PVC M12 x 500,00 mm sans tête
- espárrago de PVC M12 x 500,00 mm sin cabeza



6909010000019

- dadi in PVC per tiranti M12
- PVC nuts for stays M12
- écrous en PVC pour tirants M12
- tuercas en PVC para tirantes M12

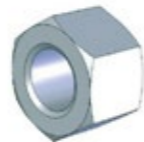

6909010000042

- rondella in PVC per tiranti M12
 - PVC stay M12 ring
 - rondelle en PVC pour tirants M12
 - arandela en PVC para tirantes M12
- Ø45,00 x 4,00 mm**



6909010000122 RAL 7025

6909010000172 RAL 9005

- tappo copri foro Ø16,00
- hole cover Ø16,00
- bouchon protège-trou Ø16,00
- tapon cubreorificio Ø16,00



6909010000074

- tappo copri foro Ø12,00 argento R9006
- hole cover Ø12,00 silver R9006
- bouchon protège-trou Ø12,00 argent R9006
- tapon cubreorificio Ø12,00 plata R9006

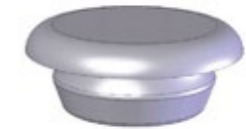

6909010000076

- tappo copri foro Ø12,00 bianco R9010
- hole cover Ø12,00 white R9010+B100
- bouchon protège-trou Ø12,00 blanc R9010
- tapon cubreorificio Ø12,00 blanco R9010



OMIPV00014 / OMIPV00014M12

- sombrero chino con dado in acciaio zincato inserito M10-M12
- sombrero Chino with nut in galvanized steel inserted M10-M12
- sombrero chino avec écrou en acier galvanisé inséré M10-M12
- sombrero chino con tuerca en acero galvanizado insertado M10-M12



INJ235

- tappo a fungo con inserto di metallo M10
- mushroom cover with metal insert M10
- bouchon de champignon avec insert métallique M10
- Hongo tornillo con inserto de metal M10



TL000002

- tappo a fungo filettato senza inserto di metallo M8/10/12
- mushroom cover without threaded metal insert M8/10/12
- bouchon de champignon sans insert métallique M8/10/12
- sombrero del hongo tornillo sin inserto de metal M8/10/12



TL0000003

- tappo a fungo filettato aperto M12
- mushroom cover threaded open M12
- bouchon de champignon enfilé ouvert M12
- sombrero del hongo rosca abierta M12



MPMR60

- rondella d.60
- washer d.60
- rondelle d.60
- arandela d.60



ACCESSORI PLASTICA PER PORTE SCORREVOLI

PLASTIC ACCESSORIES FOR SLIDING DOORS / ACCESSOIRES PLASTIQUE PORTES COULISSANTES / ACCESORIOS DE PLÁSTICO PUERTAS CORREDERAS

COLDTECH

6909010000600CT

- distanziale rigido 40 mm
- stiff spacer 40 mm
- éspaceur rigide 40 mm
- distanciador rigido 40 mm

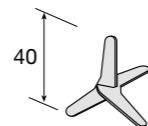

6909010000605CT

- distanziale rigido 60 mm
- stiff spacer 60 mm
- éspaceur rigide 60 mm
- distanciador rigido 60 mm

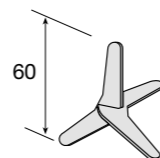

6909010000610CT

- distanziale rigido 70 mm
- stiff spacer 70 mm
- éspaceur rigide 70 mm
- distanciador rigido 70 mm

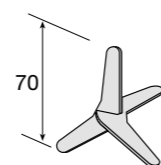

6909010000612CT

- distanziale rigido 80 mm
- stiff spacer 80 mm
- éspaceur rigide 80 mm
- distanciador rigido 80 mm

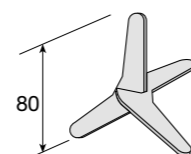

6909010000614CT

- distanziale rigido 90 mm
- stiff spacer 90 mm
- éspaceur rigide 90 mm
- distanciador rigido 90 mm

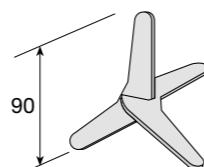

6909010000620CT

- distanziale rigido 120 mm
- stiff spacer 120 mm
- éspaceur rigide 120 mm
- distanciador rigido 120 mm

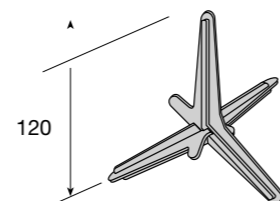

JIG000002

- gancio blocco maschio
- camlock male
- joint d'accrochage mâle
- gancho de union macho

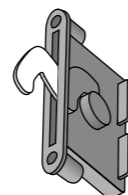

JIG000003

- gancio blocco femmina
- camlock female
- joint d'accrochage femelle
- gancho de union femenino

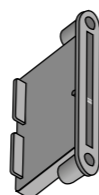

40

CERNIERE

DOOR ACCESSORIES / ACCESSOIRES PORTES / ACCESORIOS PUERTAS

COLDTECH

OMIP000012 H= 45

- cerniera reversibile a rampa
- reversible hinge at ramp
- charnière réversible à rampe
- bisagra reversible a rampa

• TN65 - 50



OMIP000013 H= 55

- cerniera reversibile a rampa
- reversible hinge at ramp
- charnière réversible à rampe
- bisagra reversible a rampa

• TN95 - 120 - 140

• BT95 - 120 - 140



OMIPCR0001 GRIGIO - GREY - GRIS - GRIS

OMIPCR0002 NERO - BLACK - NOIR - NEGRO

- cerniera a rampa reversibile con tappi nero/grigio
- black/grey reversible can hinge with plugs
- charnière réversible à rampe avec bouchons noir/gris
- bisagra y rampa reversible con tapon negro/gris

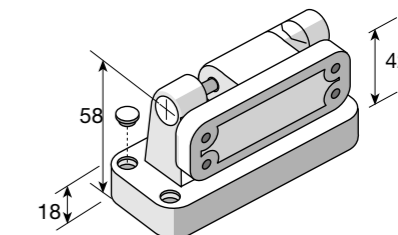

OMIPCR0010 GRIGIO - GREY - GRIS - GRIS

OMIPCR0011 NERO - BLACK - NOIR - NEGRO

- cerniera a rampa reversibile con tappi nero/grigio
- black/grey reversible can hinge with plugs
- charnière réversible à rampe avec bouchons noir/gris
- bisagra y rampa reversible con tapon negro/gris

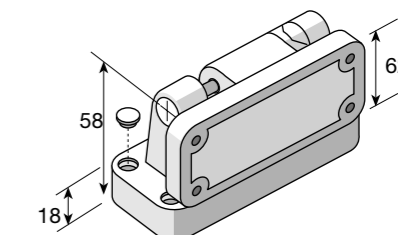

OMIPCR0020 GRIGIO - GREY - GRIS - GRIS

OMIPCR0021 NERO - BLACK - NOIR - NEGRO

- cerniera a rampa reversibile con tappi nero/grigio
- black/grey reversible can hinge with plugs
- charnière réversible à rampe avec bouchons noir/gris
- bisagra y rampa reversible con tapon negro/gris

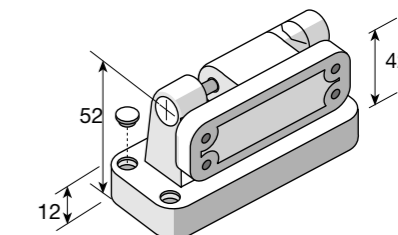

OMIPCR0030 GRIGIO - GREY - GRIS - GRIS

OMIPCR0031 NERO - BLACK - NOIR - NEGRO

- cerniera a rampa reversibile con tappi nero/grigio
- black/grey reversible can hinge with plugs
- charnière réversible à rampe avec bouchons noir/gris
- bisagra y rampa reversible con tapon negro/gris

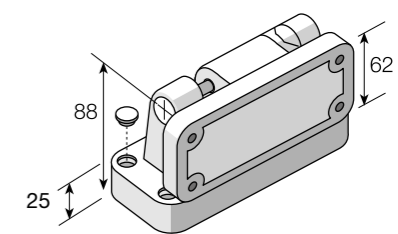

41

OMIPCR0040 GRIGIO - GREY - GRIS - GRIS

OMIPCR0041 NERO - BLACK - NOIR - NEGRO

- cerniera a rampa reversibile con tappi nero/grigio
- black/grey reversible can hinge with plugs
- charnière réversible à rampe avec bouchons noir/gris
- bisagra y rampa reversible con tapon negro/gris

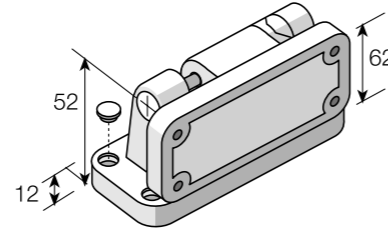

OMIPCR0200

- cerniera a rampa reversibile con tappi nero/grigio
- black/grey reversible can hinge with plugs
- charnière réversible à rampe avec bouchons noir/gris
- bisagra y rampa reversible con tapon negro/gris

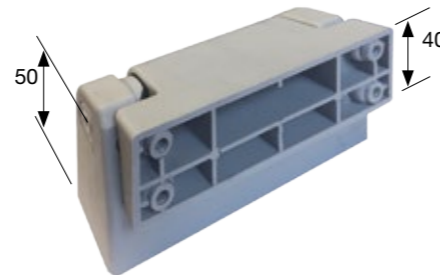

OMIPCR0100

- cerniera per battenti spessore 40mm con regolazione verticale/orizzontale
- hinge for 40-mm-thick blades with horizontal/vertical adjustment
- charnière pour vantail épaisseur 40mm avec réglage horizontal et vertical
- bisagra para oja espesor 40mm con fijacion horizontal y vertical.



OMIPCH0100

OMIPCH0101

OMIPCH0102

- spessore 5 - 10 - 20 mm
- thicker 5 - 10 - 20 mm
- épaisseur 5 - 10 - 20 mm
- espesor 5 - 10 - 20 mm



OMIPCR0400

- cerniera a rampa reversibile con tappi nero/grigio
- black/grey reversible can hinge with plugs
- charnière réversible à rampe avec bouchond noir/gris
- bisagra y rampa reversible con tapon negro/gris



6901003000014

- piatto 18,00 x 3,00 mm per collegamento telaio e controtelaio
- rectangular base bar 18,00 x 3,00 mm connection frame and counterframe
- plat 18,00 x 3,00 mm liaison huisserie et contrehuisserie
- barra rectangular 18,00 x 3,00 mm para conectar el marco y el marco auxiliar

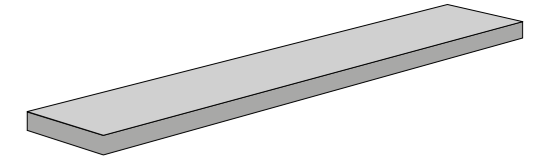

6901003000011

- piatto 20,00 x 4,00 mm nel telaio per rinforzi cerniere e ganci
- rectangular base bar 20,00 x 4,00 mm in flat frame for assembling hinges and hooks
- plat 20,00 x 4,00 mm dans la huisserie plate pour le montage des chermieres et des crochet de fermeture
- barra rectangular 20,00 x 4,00 mm en los refuerzos del marco para las bisagras y ganchos

L = 6500 mm

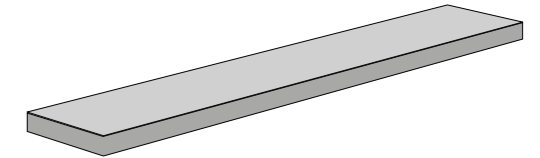

6901003000012

- piatto 30,00 x 4,00 mm nel telaio ad L per rinforzi carrucole
- rectangular base bar 30,00 x 4,00 mm in L shape frame for pulleys assembling
- plat 30,00 x 4,00 mm dans la huisserie plate pour le montages des poulies
- barra rectangular 30,00 x 4,00 mm en las poleas marco L para refuerzos

L = 6500 mm

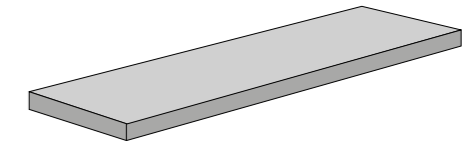

6901003000013

- piatto 50,00 x 4,00 mm nel telaio ad L per rinforzi carrucole
- rectangular base bar 50,00 x 4,00 mm in L shape frame for pulleys assembling
- plat 50,00 x 4,00 mm dans la huisserie plate pour le montages des poulies
- barra rectangular 50,00 x 4,00 mm en las poleas marco L para refuerzos

L = 6500 mm

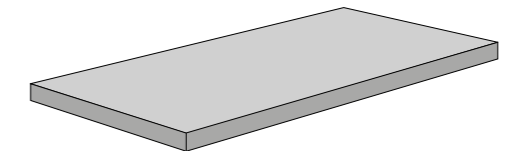

6909010000500CT (TN)

6909010000501CT (BT)

- valvola di compensazione MINI TN / BT
- compensation valves MINI TN / BT
- soupapes pour chambre froides MINI TN / BT
- valvola compensadora MINI TN / B



6909010000510CT (TN)

6909010000511CT (BT)

- valvola di compensazione STANDARD TN / BT
- compensation valves STANDARD TN / BT
- soupapes pour chambre froides STANDARD TN / BT
- valvola compensadora STANDARD TN / B



6909010000520CT (TN)

6909010000521CT (BT)

- valvola di compensazione MAXI TN / BT
- compensation valves MAXI TN / BT
- soupapes pour chambre froides MAXI TN / BT
- valvola compensadora MAXI TN / B



INT0000500

- valvola di compensazione EVO MAXI ELEBAR
- compensation valves EVO MAXI ELEBAR
- soupapes pour chambre froides EVO MAXI ELEBAR
- valvola compensadora EVO MAXI ELEBAR



JIG000001

- valvola di compensazione
- compensation valves
- soupapes pour chambre froides
- valvola compensadora



MONOUSCITA

- standard in bobina

- in rolls :watt and ohm accordingly the lenght

- en bobine:watt et ohm selon la longueur

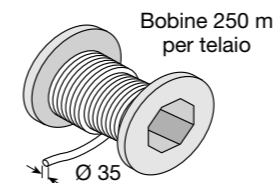

RESISTENZA 220V/24V

- DIAMETRO 3,5 mm.
- CLASSE DI PROTEZIONE II
- VALORI OHMICI DA 6.3 A 200
- TENSIONE DI ALIMENTAZIONE 230V ± 10% (50 Hz)
- POTENZA SPECIFICA DISSIPATA 30 W/m -2/+3
- CONFORME ALLE NORME IEC EN60335-1 E CENELEC HD289 S1
- TEMPERATURA SUPERFICIALE RAGGIUNGIBILE SUL CAVO: 92° C.

HEATING CABLE 220V/24V FOR FRAME

- DIAMETER 3.5 mm.
- PROTECTION CATEGORY II
- OHMIC RESISTANCE FROM 6.3 TO 200
- POWER SUPPLY 230V + 10% (50Hz)
- SPECIFIC DISSIPATED POWER 30 W/m -2/+3
- COMPLIES WITH IEC EN60335-1 AND CENELEC HD289 S1 STANDARDS
- POTENTIAL CABLE SURFACE TEMPERATURE: 92° C

CORDON CHAUFFANT 220V/24V V POUR BATI

- DIAMÈTRE 3,5 mm.
- CLASSE DE PROTECTION II
- VALEURS OHMIQUES DE 6,3 à 200
- TENSION D'ALIMENTATION 230 V ±10% (50 Hz)
- PUISSANCE SPÉCIFIQUE DISSIPÉE 30 W/m -2/+3
- CONFORME AUX NORMES CEI EN 60335-1 et CENELEC HD289 S1
- TEMPÉRATURE SUPERFICIELLE POUVANT ÊTRE ATTEINTE SUR LE CORDON: 92°C.

RESISTENCIA CALEFACTORIA 220V/24V PARA MARCO

- DIÁMETRO: 3,5 mm
- CLASE DE PROTECCIÓN: II
- VALORES ÓHMICOS: DE 6,3 A 200
- TENSIÓN DE ALIMENTACIÓN: 230 V ± 10% (50 Hz)
- POTENCIA ESPECÍFICA DISIPADA: 30 W/m-2/+3
- EN CONFORMIDAD CON LAS NORMATIVAS IEC EN60335-1 Y CENELEC HD289 S1
- TEMPERATURA SUPERFICIAL ALCANZABLE EN EL CABLE: 92°C

GAMMA LUNGHEZZE

- DA 5,9 A 6,5 mt.
- DA 6,6 A 7,5 mt.
- DA 7,6 A 8,5 mt.
- DA 9,6 A 10,5 mt.
- DA 10,6 A 11,5 mt.
- DA 13,1 A 14 mt.
- DA 15,6 A 16,5 mt.
- DA 16,6 A 17,5 mt.
- DA 4,7 A 5,2 mt.
- DA 3 A 3,5 mt.
- DA 3,6 A 4,1 mt.
- DA 4,2 A 4,6 mt.
- DA 5,3 A 5,8 mt
- DA 8,6 A 9,5 mt.
- DA 11,6 A 13 mt.
- DA 14,1 A 15,5 mt..

TAGLIATI SU MISURA

- like standard but prepared and cutte by single lenght
- standard mais coupe' en pieces

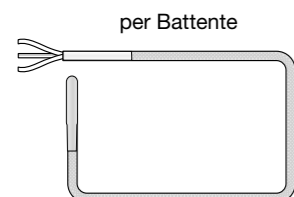

RESISTENZA 24V

- DIAMETRO 5,0 mm.
- CLASSE DI PROTEZIONE II
- TENSIONE DI ALIMENTAZIONE 24 V
- POTENZA SPECIFICA DISSIPATA 30 W/m -2/+3
- CONFORME ALLE NORME IEC EN60335-1 E CENELEC HD289 S1

HEATING CABLE 24 V FOR BLADE

- DIAMETER 5.0 mm.
- PROTECTION CATEGORY II
- POWER SUPPLY 24 V
- SPECIFIC DISSIPATED POWER 27 W/m-2/+3
- COMPLIES WITH IEC EN60335-1 AND CENELEC HD289 S1 STANDARDS
- HEATING CABLE DATA SHOWN ON EACH SAMPLE
- POTENTIAL CABLE SURFACE TEMPERATURE: 92° C

CORDON CHAUFFANT 24 V POUR VANTAIL

- DIAMÈTRE 5,0 mm.
- CLASSE DE PROTECTION II.
- TENSION D'ALIMENTATION 24 V
- PUISSANCE SPÉCIFIQUE DISSIPÉE 27 W/m-2/+3
- CONFORME AUX NORMES CEI EN 60335-1 ET CENELEC HD289 S1
- CARACTÉRISTIQUES DU CORDON CHAUFFANT REPORTÉES SUR CHAQUE ÉCHANTILLON

RESISTENCIA CALEFACTORIA 24 V PARA BATIENTE

- DIÁMETRO: 5,0 mm
- CLASE DE PROTECCIÓN: II
- TENSIÓN DE ALIMENTACIÓN: 24 V
- POTENCIA ESPECÍFICA DISIPADA: 27 W/m -2/+3
- EN CONFORMIDAD CON LAS NORMATIVAS IEC EN60335-1 Y CENELEC HD289 S1
- DATOS DEL CABLE DE CALENTAMIENTO INDICADOS EN TODAS LAS MUESTRAS

GAMMA LUNGHEZZE

4,84 mt.	8,74 mt.
5,14 mt.	8,94 mt.
5,34 mt.	9,14 mt.
5,54 mt.	9,34 mt.
5,74 mt.	9,54 mt.
5,94 mt.	9,74 mt.
6,14 mt.	9,94 mt.
6,34 mt.	10,14 mt.
6,54 mt.	10,34 mt.
6,74 mt.	10,54 mt.
6,94 mt.	10,74 mt.
7,14 mt.	10,94 mt.
7,34 mt.	11,14 mt.
7,54 mt.	11,34 mt.
7,74 mt.	11,54 mt.
7,94 mt.	11,74 mt.
8,14 mt.	11,94 mt.
8,34 mt.	12,14 mt.
8,54 mt.	

POTERE COSTANTE

- constant power
- puissance constante

CAL0000020

- resistenza potenza costante d.3 senza maglia metallica
- constant power d.3 without metallic protection
- cordon chaffant à puissances d.3 sans protection métallique
- resistencia con potencia constante d.3 sin proteccion metalica



CAL0000021

- resistenza potenza costante d.3 con protezione metallica
- constant power d.3 with metallic protection
- cordon chaffant à puissances d.3 avec protection métallique
- resistencia con potencia constante d.3 con proteccion metalica



CAL0000022

- resistenza potenza costante d.5 con protezione metallica
- constant power d.5 with metallic protection
- cordon chaffant à puissances d.5 avec protection métallique
- resistencia con potencia constante d.5 con proteccion metalica



CAL0000023

- resistenza potenza costante d.5 senza maglia metallica
- constant power d.5 without metallic protection
- cordon chaffant à puissances d.5 sans protection métallique
- resistencia con potencia constante d.5 sin proteccion metalica



CAL0000008

- kit di montaggio
- kit for assembling
- kit pour l'assemblage
- kit para El montaje





Automation system 148 designed for cold room doors WITH FRAME

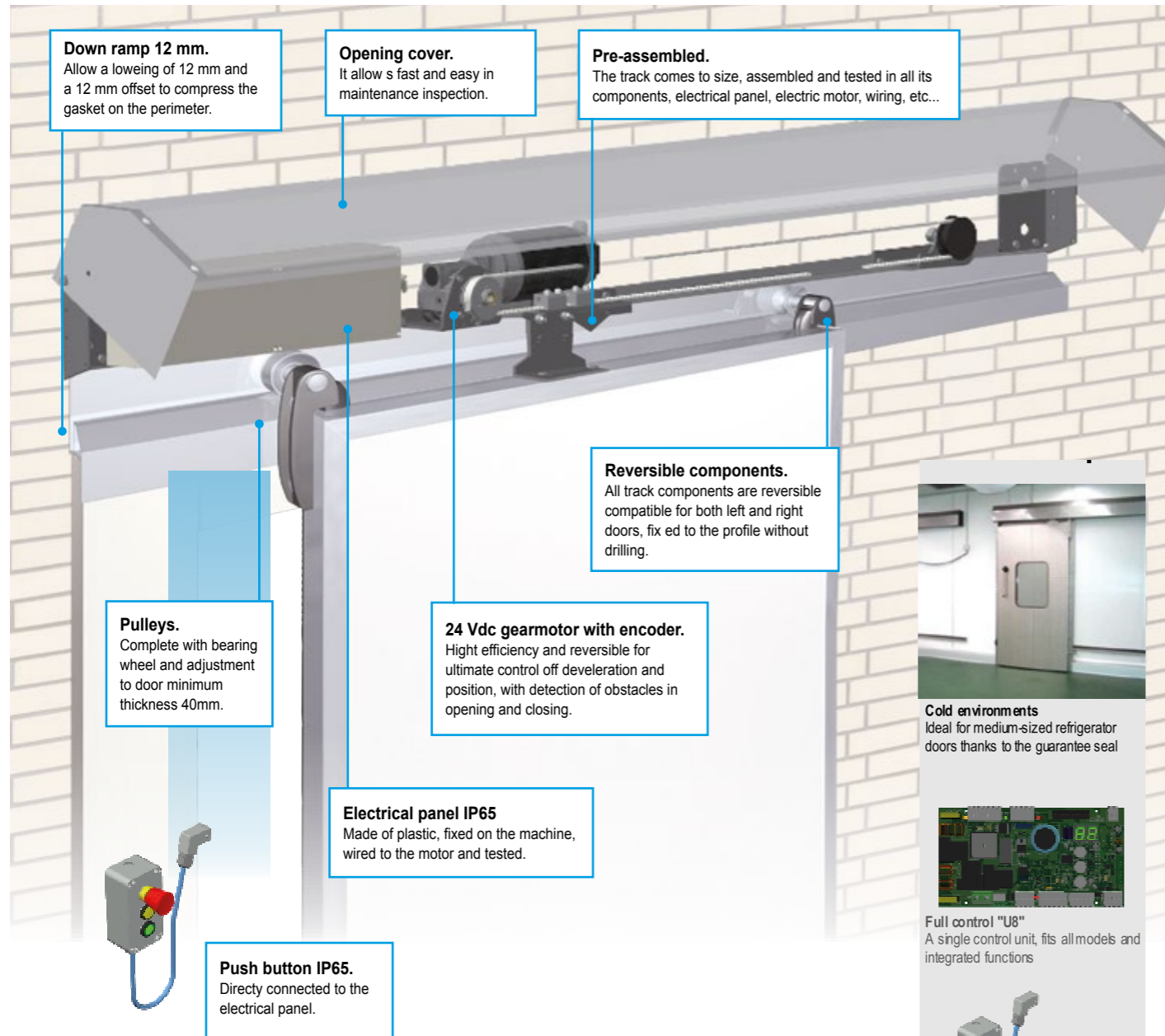

Down ramp 12 mm.
Allow a lowering of 12 mm and a 12 mm offset to compress the gasket on the perimeter.

Opening cover.
It allows fast and easy maintenance inspection.

Pre-assembled.
The track comes to size, assembled and tested in all its components, electrical panel, electric motor, wiring, etc...

Reversible components.
All track components are reversible compatible for both left and right doors, fixed to the profile without drilling.

Pulleys.
Complete with bearing wheel and adjustment to door minimum thickness 40mm.

24 Vdc gearmotor with encoder.
High efficiency and reversible for ultimate control of deceleration and position, with detection of obstacles in opening and closing.

Electrical panel IP65
Made of plastic, fixed on the machine, wired to the motor and tested.

Push button IP65.
Directly connected to the electrical panel.

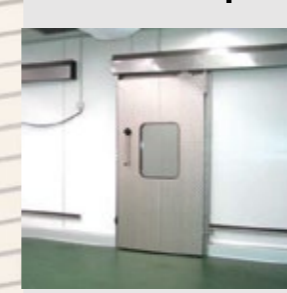

Cold environments
Ideal for medium-sized refrigerator doors thanks to the guarantee seal

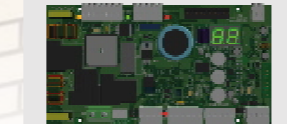

Full control "U8"
A single control unit, fits all models and integrated functions

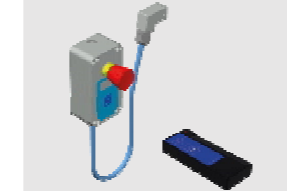

Remote programmer
Ability to remotely program all functions of the door without opening the electrical panel

Advantages of a 24 Vdc automation

- **Obstacle detection** the 24 Vdc electronics constantly analyzes the proper functioning of the door by operating the reversal of the movement, in the event of contact with any obstacles
- **Anti black-out** in case of absence of electrical energy, the control unit 24Vdc activates the emergency batteries to open and close the door
- **Fast openings** the 24 Vdc electronics allows fine adjustment of the operating speed and a combination of smooth and quiet door



Kit with chain (belt) holder profile WIRED

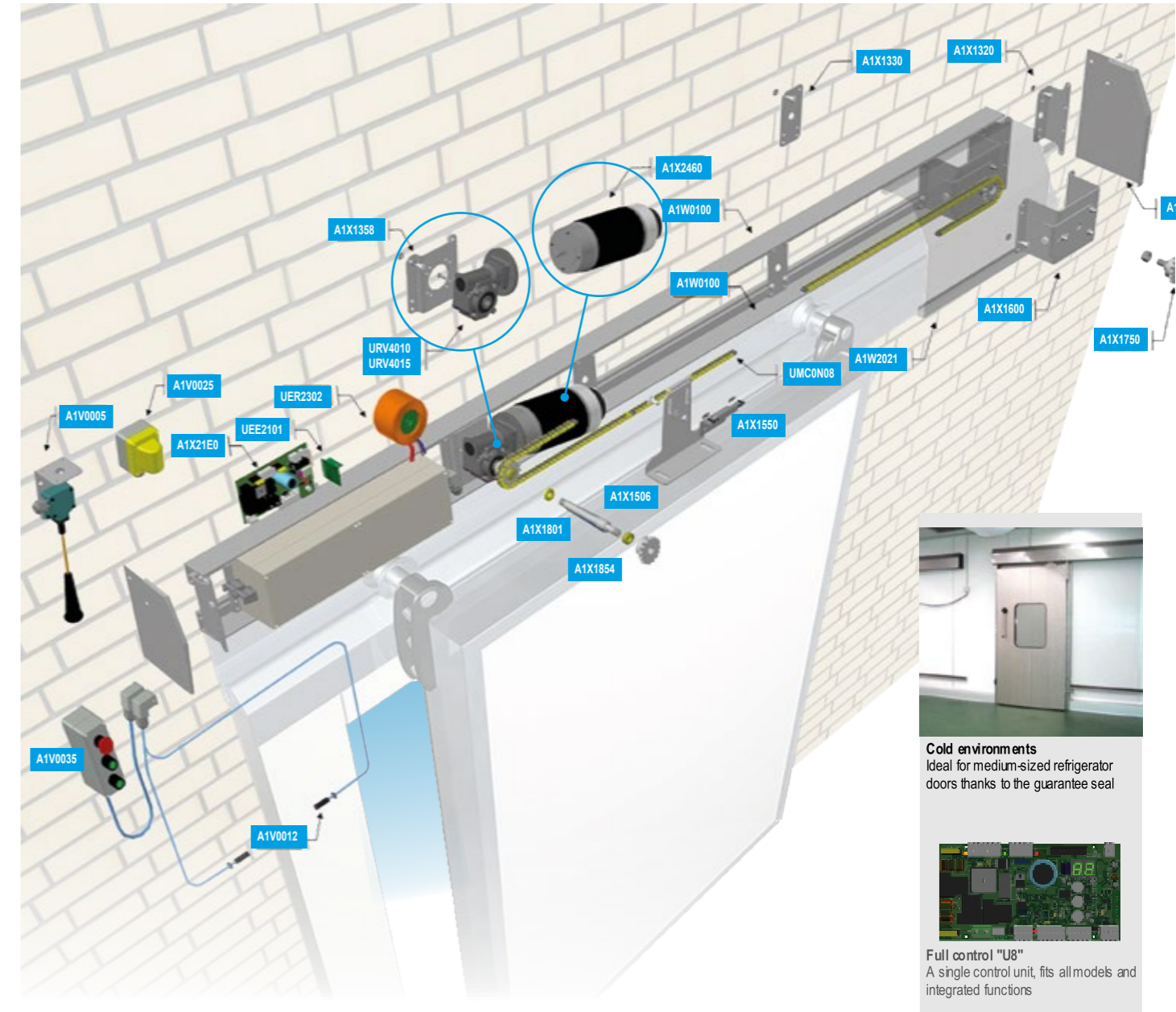

Cold environments
Ideal for medium-sized refrigerator doors thanks to the guarantee seal

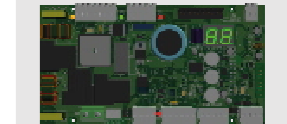

Full control "U8"
A single control unit, fits all models and integrated functions

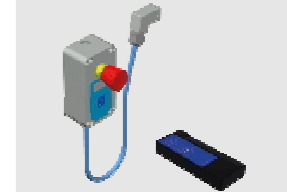

Remote programmer
Ability to remotely program all functions of the door without opening the electrical panel

Advantages of a 24 Vdc automation

- **Obstacle detection** the 24 Vdc electronics constantly analyzes the proper functioning of the door by operating the reversal of the movement, in the event of contact with any obstacles
- **Anti black-out** in case of absence of electrical energy, the control unit 24Vdc activates the emergency batteries to open and close the door
- **Fast openings** the 24 Vdc electronics allows fine adjustment of the operating speed and a combination of smooth and quiet door



kit without chain (belt) holder profile WIRED

A1X1412 belt

A1X1414 chain

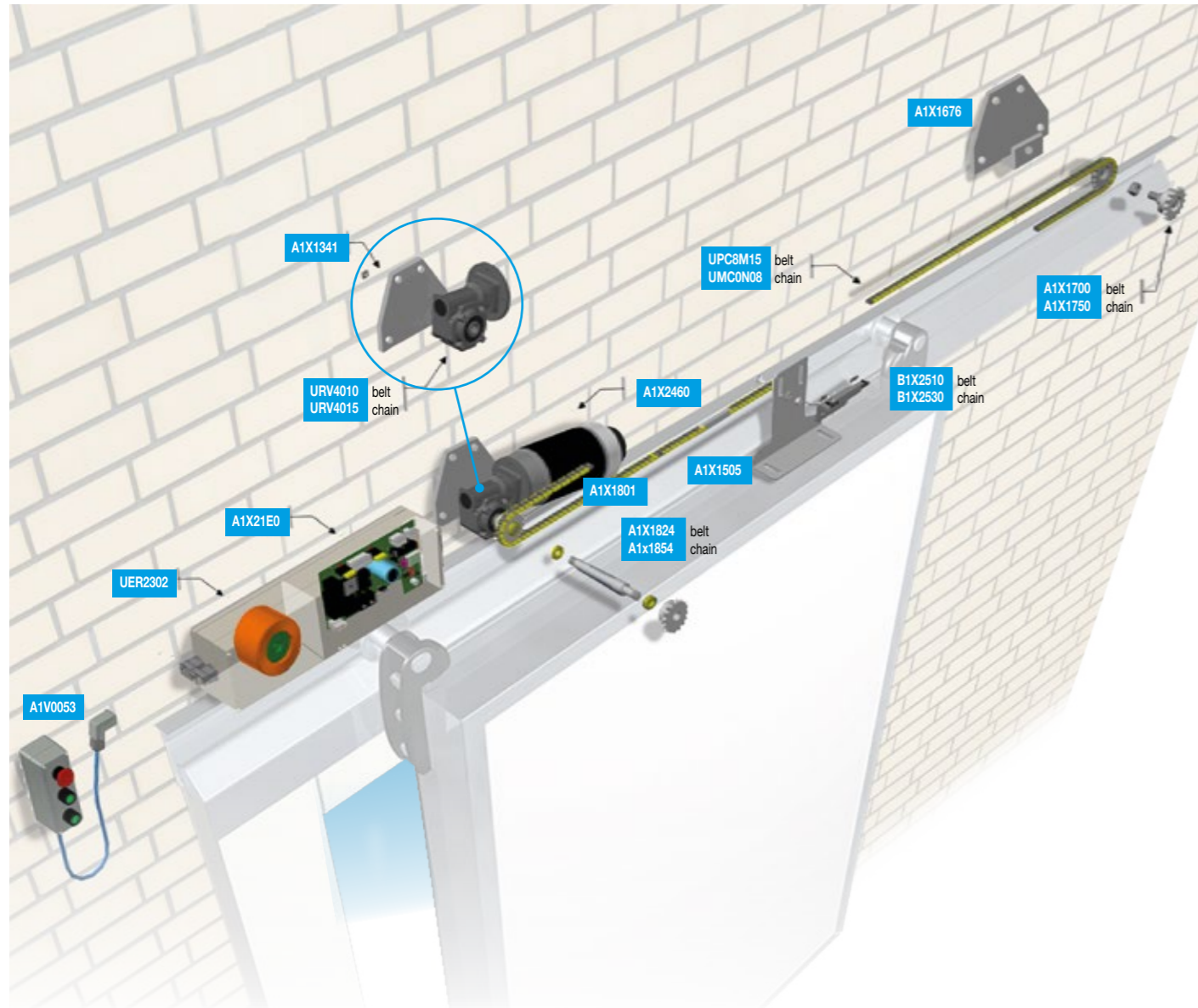

Advantages of a 24 Vdc automation

- **Obstacle detection** the 24 Vdc electronics constantly analyzes the proper functioning of the door by operating the reversal of the movement, in the event of contact with any obstacles
- **Anti black-out** in case of absence of electrical energy, the control unit 24Vdc activates the emergency batteries to open and close the door
- **Fast openings** the 24 Vdc electronics allows fine adjustment of the operating speed and a combination of smooth and quiet door



Kit Motor and electronic components NOT WIRED

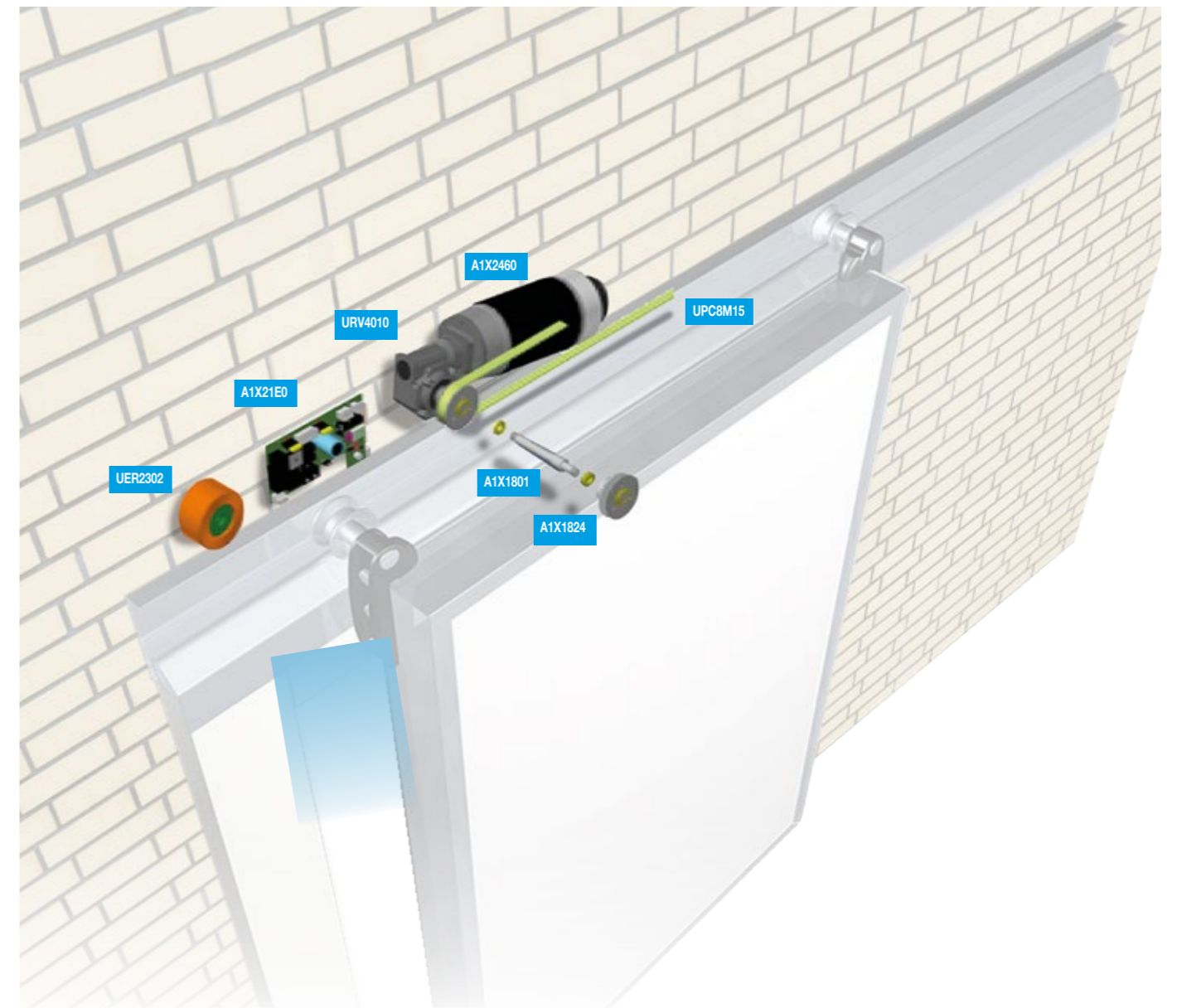

Advantages of a 24 Vdc automation

- **Obstacle detection** the 24 Vdc electronics constantly analyzes the proper functioning of the door by operating the reversal of the movement, in the event of contact with any obstacles
- **Anti black-out** in case of absence of electrical energy, the control unit 24Vdc activates the emergency batteries to open and close the door
- **Fast openings** the 24 Vdc electronics allows fine adjustment of the operating speed and a combination of smooth and quiet door



Mechanical components

URV3010 Worm gearbox ratio 1:10

URV3015 Worm gearbox ratio 1:15

Aluminium alloy housing, high efficiency for A1X2450 120W motor



URV4010 Worm gearbox ratio 1:10

URV4015 Worm gearbox ratio 1:15

Aluminium alloy housing, high efficiency for A1X2460 250W motor



B1X2710 VSF complete motor shaft D=14
Motor shaft for worm gearbox URV30__ complete with self-locking ring nuts and splines
Material: stainless steel

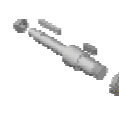

A1X1801 VSF complete motor shaft D=19
Motor shaft for worm gearbox URV40__ complete with self-locking ring nuts and splines
Material: stainless steel



UPC8M15 Toothed belt HTD8
High-strength HTD8 profile internally reinforced with steel
Material: polyurethane in White



UMC0N08 Roller chain 1/2"
Material: tempered steel



A1X1700 Complete idler pulley
On shielded ball bearing
Material: stainless steel and high-strength thermoplastic



A1X1750 Complete 1/2" chain idler pulley gear wheel on shielded ball bearing
Material: galvanized steel



A1X1824 Complete motor pinion Z24
Pinion for HTD8 toothed belt
Material: stainless steel

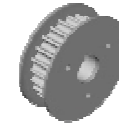

A1X1852 Complete Z16 motor pinion
Pinion for 1/2" roller chain
Material: galvanized steel

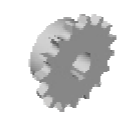

B1X2510 Complete belt tensioner clamp HTD8
Same model for left and right-hand sliding doors
Material: galvanized steel



B1X2530 Complete chain clamp
Same model for left and right-hand sliding doors
Material: galvanized steel



Electrical components

A1V0005 Pull cord switch
complete with stainless steel bracket, cable and knob



UEE2101 433 MHz plug-in receiver
Superheterodyne radio receiver to be plugged directly into the control board



A1V0065 RADIO pull cord switch 433 MHz
IP65 box with cable and knob, code programmable via dip switches (1024 combinations)



A1V0064 433 MHz four-channel remote control
IP65 plastic box, remote control, code programmable via dip switches (1024 combinations)



A1V0012 PNP Photocell kit
Infrared barrier consisting just of a pair of compact sensors with built-in electronics, complete with connector to be connected directly to control board



UEE2141 433 MHz four-channel remote control
Remote control, code programmable via dip switches (1024 combinations)



A1V0015 Backup battery kit 3.3 A series 147/149
backup batteries for operation in the event of a power failure



UEE2151 433 MHz wireless keyboard
Remote control, programmable code (99999 combinations)



A1V0025 24Vdc flashing light
in yellow, complete with bulb and cable clamp



UEE2130 Complete infrared programmer
Can be used for programming a short distance from the display without opening the electrical panel. (the display must be visible)



A1V0053 Standard push button
In plastic material IP65 with START, STOP and PARTIAL button



A1X2460 24Vdc 250W motor
Direct current electric motor with high starting torque, essential for lifting the sliding door off the ramps during opening.



A1V0058 Push button with display
In plastic material IP65 with START, STOP and two-digit display



A1X2450 24Vdc 120W motor
Direct current electric motor with high starting torque, essential for lifting the sliding door off the ramps during opening.



A1V0051 Push button with 1 start
In plastic material IP65 with START button



A1X21E0 24Vdc control board + display
designed to operate the 24Vdc motors, the controller includes a two-digit remote display

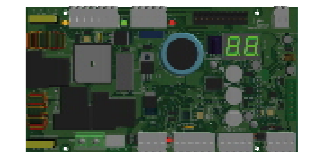

A1V0061 Wireless push button 433 MHz with 1 start
In plastic material IP65 with START button and programmable with dip-switch (1024 combinations)



UER2302 250VA 230V transformer
Double-insulated toroidal transformer insulation class B



UER2301 150VA 230V transformer
Double-insulated toroidal transformer insulation class B



COLDTECH



BATTENTE / DOORBLADE



IK8100

- maniglia a leva int. + ext. universale
- level handle int. + ext.
- poignée int. + ext. a levier
- maneta int. + ext. de palanca



VIB000010

- profilo battente da 109,5 mm non schiumato
- door leaf profile 109,5 mm not foamed
- profil bord vantail 109,5 mm ne pas injectée
- perfil borde batiente 109,5 mm no inyectados



ISE000007

- guarnizione inferiore base larga
- lower gasket wide strip
- joint inférieur base large
- burlete inferior base grande



ISE000011

- guarnizione inferiore con passaggio resistenza
- lower gasket with heating cable passage
- joint inférieur avec résistance passage
- burlete inferior puerta con paso resistencia



690900200053

- serratura porte scorrevoli
- lock for sliding doors
- fermeture pour portes coulissantes
- cierre para puertas corredizas



OMPV00020

- registro grande per guida inferiore reversibile per porte simmetriche
- reversible rear register big for lower guide symmetric door
- registre grand pour guide inférieur reversible symmetric portes
- registro grande en el riel inferior puertas simétricas

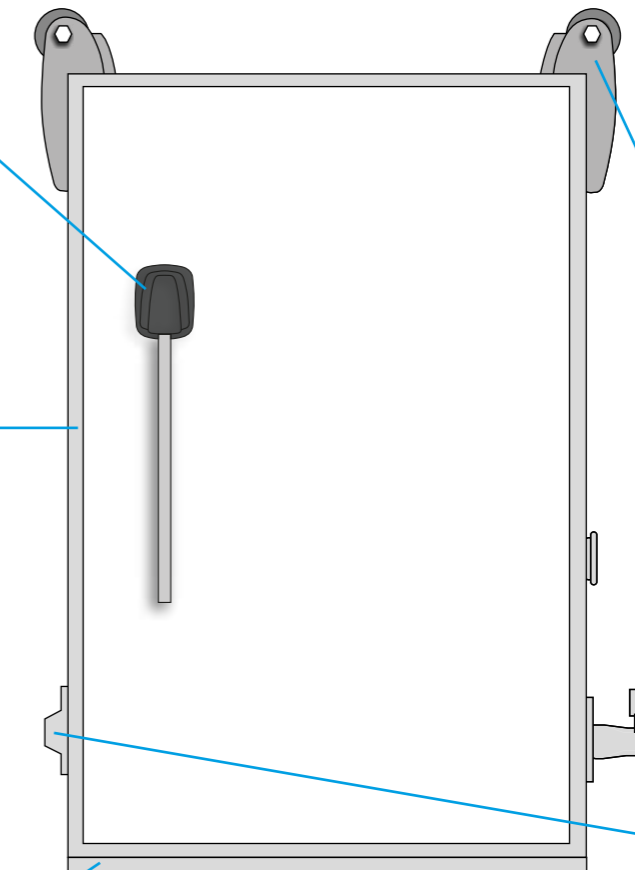

- OMP000004 (dx)**
OMP000005 (sx)
- carrucola completa dx/sx in plastica con perno da 160 o 180 mm
 - complete rh/l-hand plastic sheave with pin from 160 or 180 mm
 - poulie complète droite/gauche en plastique avec la broche de 160 ou 180 mm
 - polea completa dcha/izqda en plástico con el pasador de 160 ou 180 mm



OMPV00004

- riscontro per gancio di chiusura inferiore
- striker for lower latch hook
- correspondance pour crochet fermeture inférieur
- anclaje para gancho de cierre inferior



ISE000009

- guarnizione perimetrale coestrusa base larga
- coextruded perimetric gasket wide strip
- joint périphérique coextrudée base large
- burlete perimetral coextrusionado base grande



ISE00002CT

- guarnizione perimetrale con passaggio resistenza base larga
- perimetric gasket with resistance passage wide strip
- joint périphérique avec résistance passage base large
- burlete perimetral con paso resistencia base grande



690901000093 RAL 7025
6909010000149 RAL 9010

- cuneo in NYLON H = 22,00 mm
- NYLON wedge H = 22,00 mm
- cale en NYLON H = 22,00 mm
- cuña en NYLON H = 22,00 mm

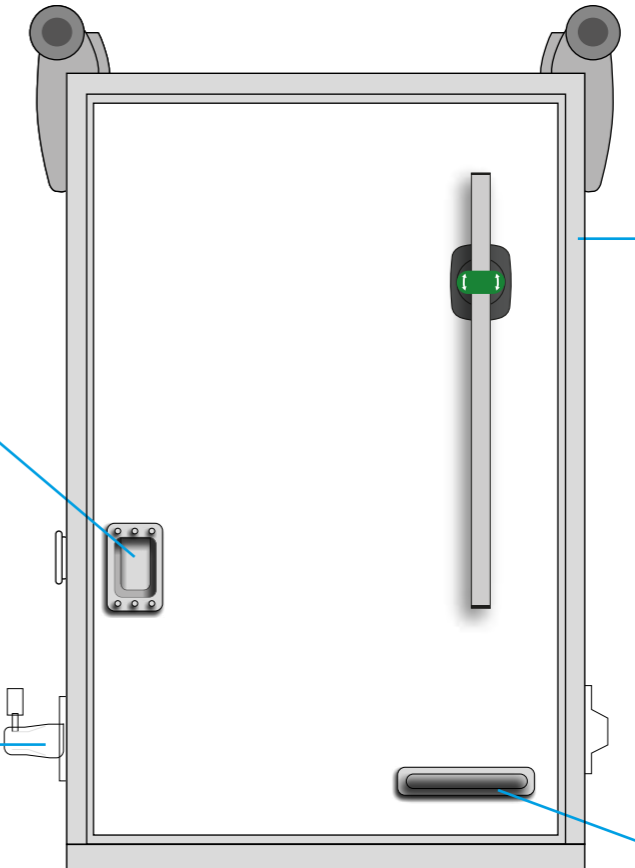

PORTE SCORREVOLI MANUALI

MANUAL SLIDING DOORS / PORTES COULISSANTES MANUELS / PUERTAS CORREDIZAS MANUALES

TELAIO SUPERIORE / HIGHER FRAME

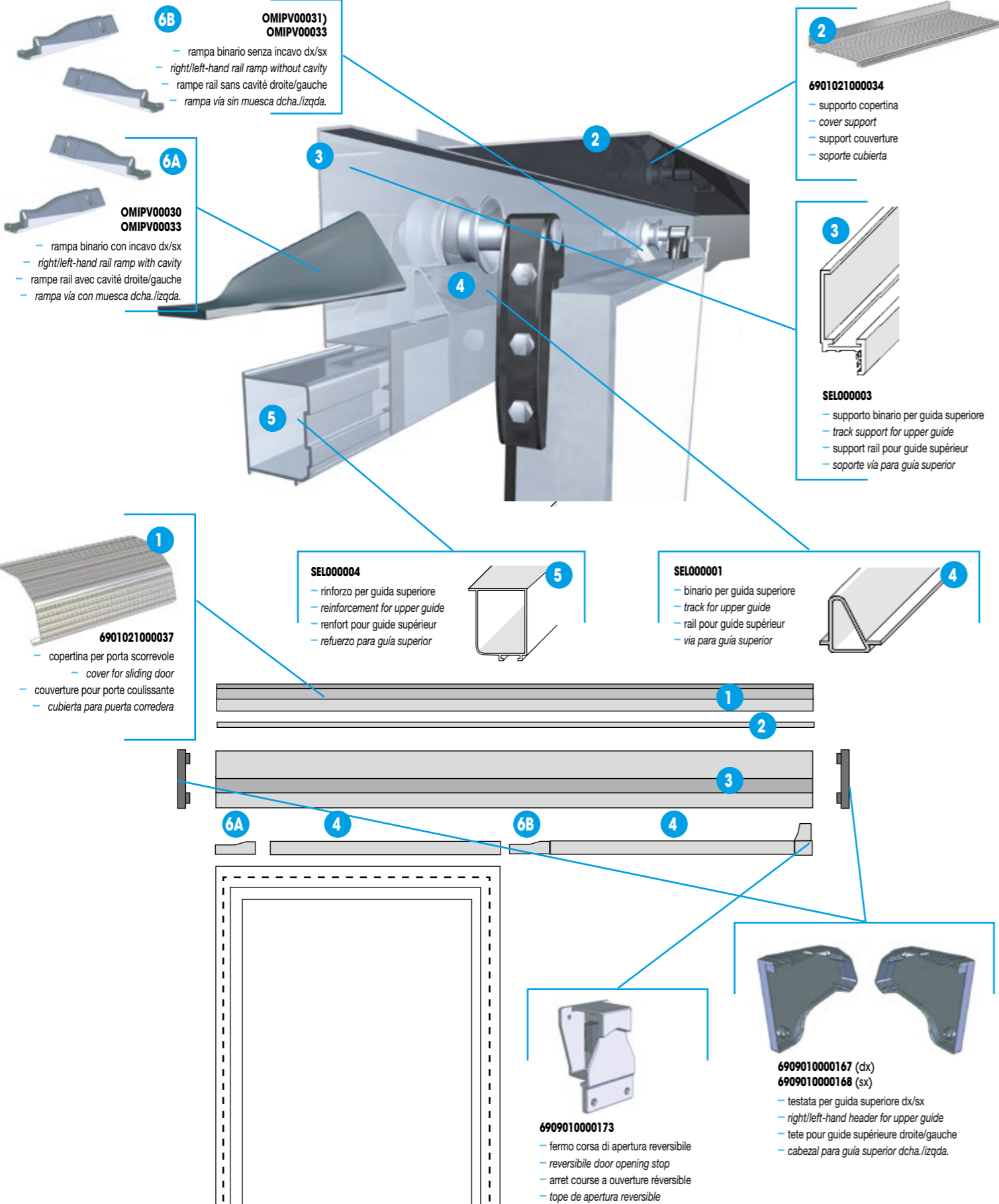

PORTE SCORREVOLI MANUALI

MANUAL SLIDING DOORS / PORTES COULISSANTES MANUELS / PUERTAS CORREDIZAS MANUALES

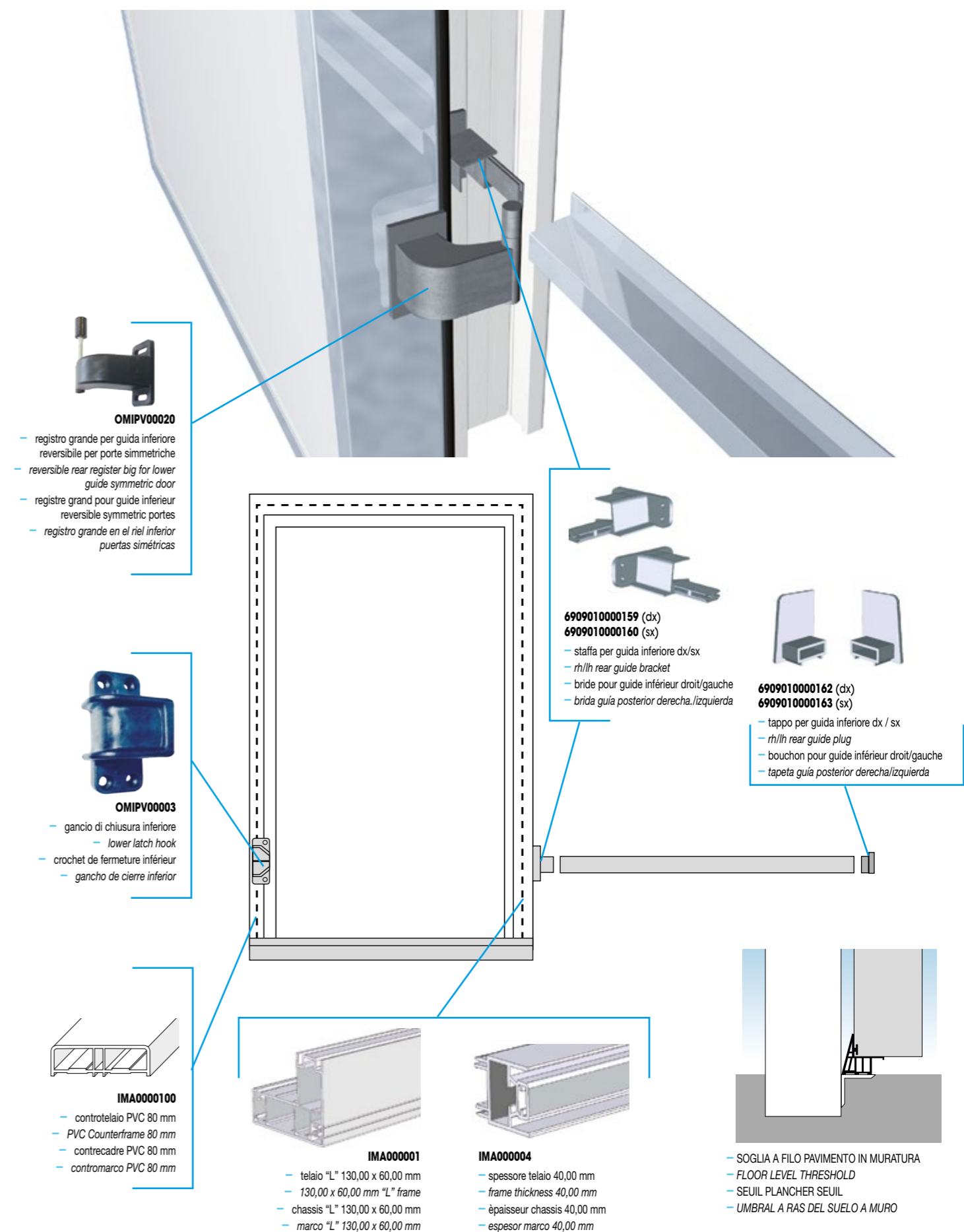

PORTE SCORREVOLI MANUALI

MANUAL SLIDING DOORS / PORTES COULISSANTES MANUELS / PUERTAS CORREDIZAS MANUALES

2 BATTENTI / 2 BLADE

6909004000068

- carrucola per porte 2 ante reversibile
- reversible sheave for 2-leaf door
- poulie pour porte 2 volets réversible
- polea para puerta 2 hojas reversible

6901021000016

- bordo battente 140,00 mm schiumato
- door leaf profile edge 140,00 mm foamed
- bord battant 140,00 mm injectée
- borde batiente 140,00 mm inyectados

CAL0000021

- resistenza potenza costante d.3 con protezione metallica
- constant power d.3 with metallic protection
- cordon chauffant à puissances d.3 avec protection métallique
- resistencia con potencia constante d.3 con protección metálica

OMIP000004 (dx)
OMIP000005 (sx)

- carrucola completa dx/sx in plastica con perno da 160 o180 mm
- complete rh/lt-hand plastic sheave with pin from 160 or180 mm
- poulie complète droite/gauche en plastique avec la broche de 160 ou180 mm
- polea completa dcha/izqda en plástico con el pasador de 160 ou180 mm

OMIPV00020

- registro per guida inferiore reversibile per porte simmetriche
- reversible rear register for lower guide for symmetric doors
- registre pour guide inférieur réversible pour portes symétriques
- registro guía inferior reversible para puertas simétricas

6909010000093 RAL 7025
6909010000149 RAL 9010

- cuneo in NYLON H = 22,00 mm
- NYLON wedge H = 22,00 mm
- cale en NYLON H = 22,00 mm
- cuña en NYLON H = 22,00 mm

ISE000007

- guarnizione inferiore base larga
- lower gasket wide strip
- joint inférieur base large
- burlete inferior base grande

ISE000011

- guarnizione inferiore con passaggio resistenza
- lower gasket with heating cable passage
- joint inférieur avec résistance passage
- burlete inferior puerta con paso resistencia

ISE000009

- guarnizione perimetrale coestrusa base larga
- coextruded perimetric gasket wide strip
- joint périmétral coextrudée base large
- burlete perimetral coextrusionado base grande

ISE00002CT

- guarnizione perimetrale con passaggio resistenza base larga
- perimetric gasket with resistance passage wide strip
- joint périmétral avec résistance passage base large
- burlete perimetral con paso resistencia base grande

6909003000090

- maniglia esterna fissa frontale
- fixed external front handle
- poignée externe fixe frontale
- Manilla externa fija frontal

IK8100

- maniglia a leva int. + ext. universale
- level handle int. + ext.
- poignée int. + ext. a levier
- maneta int. + ext. de palanca

6909010000173

- fermo corsa di apertura reversibile
- reversible door opening stop
- arret course a ouverture réversible
- tope de apertura reversible

6909010000163 (sx)

- tappo per guida inferiore dx
- rh rear guide plug
- bouchon pour guide inférieur droite
- tapeta guía posterior izquiera

6909010000162 (dx)

- tappo per guida inferiore dx
- right rear guide plug
- bouchon pour guide inférieur droit
- tapeta guía posterior izquiera

6909010000159 (dx)

- staffa per guida inferiore sx
- right rear guide bracket
- bride pour guide inférieur droit
- brida guía posterior izquiera

6909010000173

- fermo corsa di apertura reversibile
- reversible door opening stop
- arret course a ouverture réversible
- tope de apertura reversible

PORTE SCORREVOLI MANUALI

MANUAL SLIDING DOORS / PORTES COULISSANTES MANUELS / PUERTAS CORREDIZAS MANUALES

TELAIO / FRAME

SEL000003

- supporto binario per guida superiore
- track support for upper guide
- support rail pour guide supérieur
- soporte vía para guía superior

SEL000004

- rinforzo per guida superiore
- reinforcement for upper guide
- renfort pour guide supérieur
- refuerzo para guía superior

SEL000001

- binario per guida superiore
- track for upper guide
- rail pour guide supérieur
- vía para guía superior

SEL000002

- guida inferiore
- lower guide
- guide inférieur
- guía inferior

OMIPV00033

- rampa binario senza incavo sx
- left-hand rail ramp without cavity
- rampe rail sans cavité gauche
- rampa via sin muesca izquierda

OMIPV00030
OMIPV00032

- rampa binario con incavo dx/sx
- right/left-hand rail ramp with cavity
- rampe rail avec cavité droite/gauche
- rampa via con muesca dcha./izqda.

OMIPV00031

- rampa binario senza incavo dx
- right hand rail ramp without cavity
- rampe rail sans cavité droite
- rampa via sin muesca dcha.

6909010000173

- fermo corsa di apertura reversibile
- reversible door opening stop
- arret course a ouverture réversible
- tope de apertura reversible

6909010000163 (sx)

- tappo per guida inferiore dx
- rh rear guide plug
- bouchon pour guide inférieur droite
- tapeta guía posterior izquiera

6909010000162 (dx)

- tappo per guida inferiore dx
- right rear guide plug
- bouchon pour guide inférieur droit
- tapeta guía posterior izquiera

6909010000159 (dx)

- staffa per guida inferiore sx
- right rear guide bracket
- bride pour guide inférieur droit
- brida guía posterior izquiera

IMA0000001

- telaio "L" 130,00 x 60,00 mm
- 130,00 x 60,00 mm "L" frame
- chassis "L" 130,00 x 60,00 mm
- marco "L" 130,00 x 60,00 mm

IMA0000004

- spessore telaio 40,00 mm
- frame thickness 40,00 mm
- épaisseur chassis 40,00 mm
- espesor marco 40,00 mm

IMA0000100

- controtelaio PVC 80 mm
- PVC Counterframe 80 mm
- contrecadre PVC 80 mm
- contramarca PVC 80 mm

6909010000160 (sx)

- staffa per guida inferiore sx
- rh rear guide bracket
- bride pour guide inférieur gauche
- brida guía posterior/izquierda

PORTE SU CERNIERA

DOORS ON HINGES / PORTES SUR CHARNIÈRE / PUERTAS SOBRE BISAGRA

BATTENTE E TELAIO DOORBLADE AND FRAME

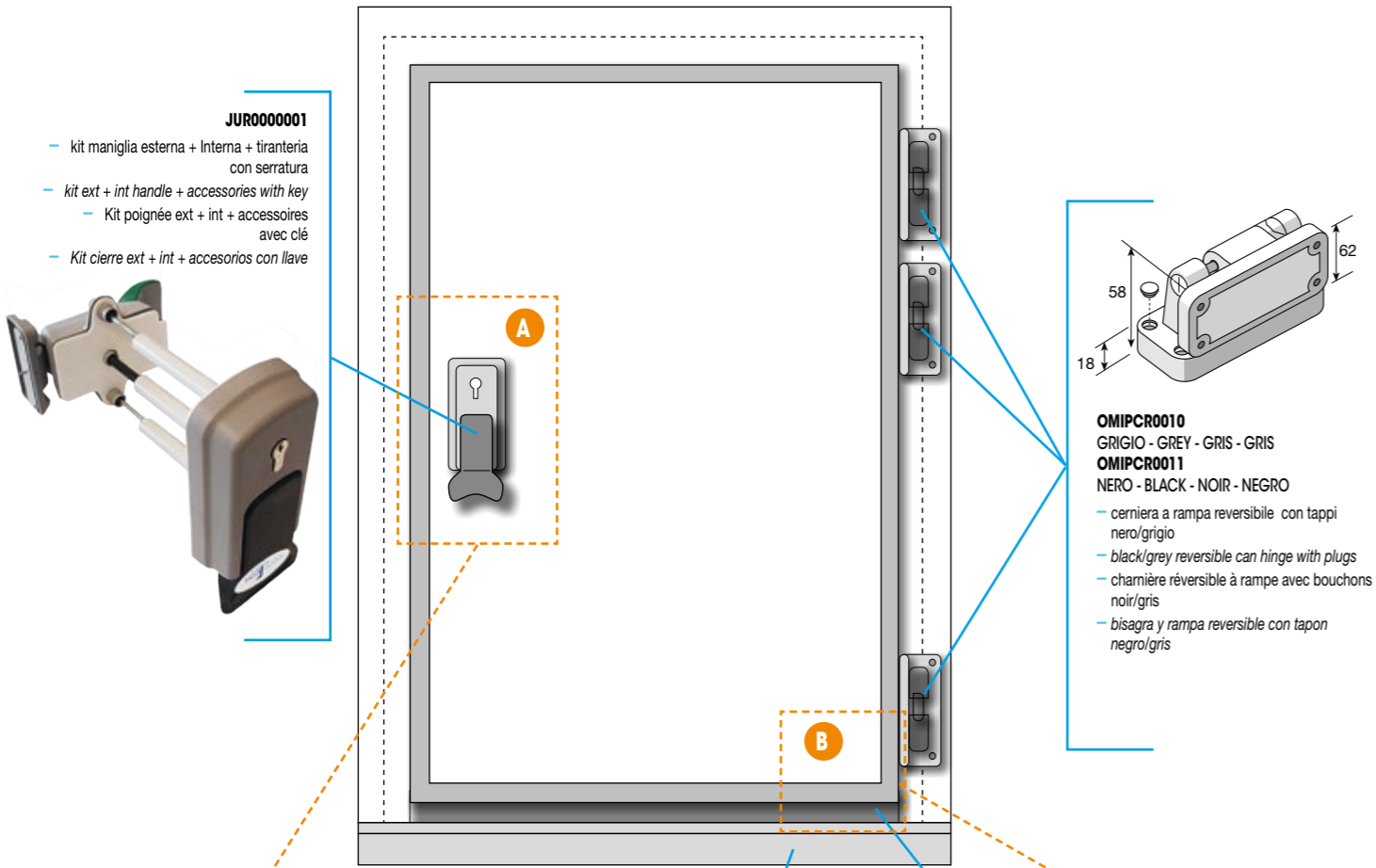

JUR0000001

- kit maniglia esterna + Interna + tiranteria con serratura
- kit ext + int handle + accessories with key
- Kit poignée ext + int + accessoires avec clé
- Kit cierre ext + int + accesorios con llave

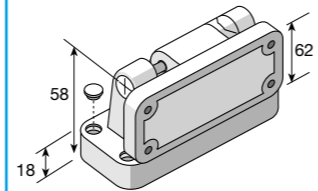

OMIPCR0010

GRIGIO - GREY - GRIS - GRIS

OMIPCR0011

NERO - BLACK - NOIR - NEGRO

- cerniera a rampa reversibile con tappi nero/grigio
- black/grey reversible can hinge with plugs
- charnière réversible à rampe avec bouchons noir/gris
- bisagra y rampa reversible con tapon negro/gris

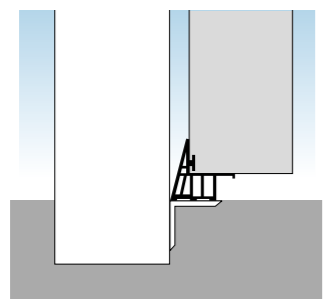
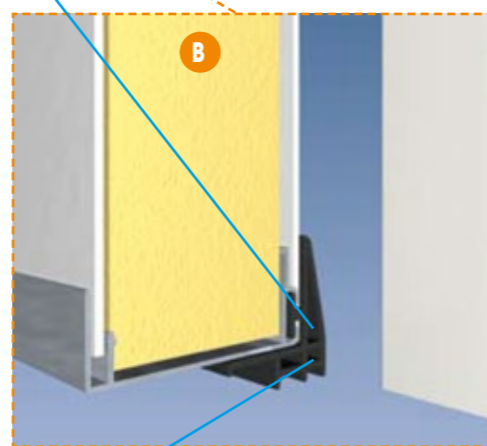

- SOGLIA A FILO PAVIMENTO IN MURATURA
- FLOOR LEVEL THRESHOLD
- SEUIL PLANCHER SEUIL
- UMBRAL A RAS DEL SUELO A MURO



ISE000007

- guarnizione inferiore base larga
- lower gasket wide strip
- joint inférieur base large
- burlete inferior base grande

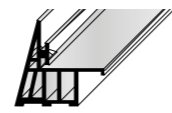

ISE000011

- guarnizione inferiore con passaggio resistenza
- lower gasket with heating cable passage
- joint inférieur avec résistance passage
- burlete inferior puerta con paso resistencia

PORTE SU CERNIERA

DOORS ON HINGES / PORTES SUR CHARNIÈRE / PUERTAS SOBRE BISAGRA

BATTENTE E TELAIO DOORBLADE AND FRAME

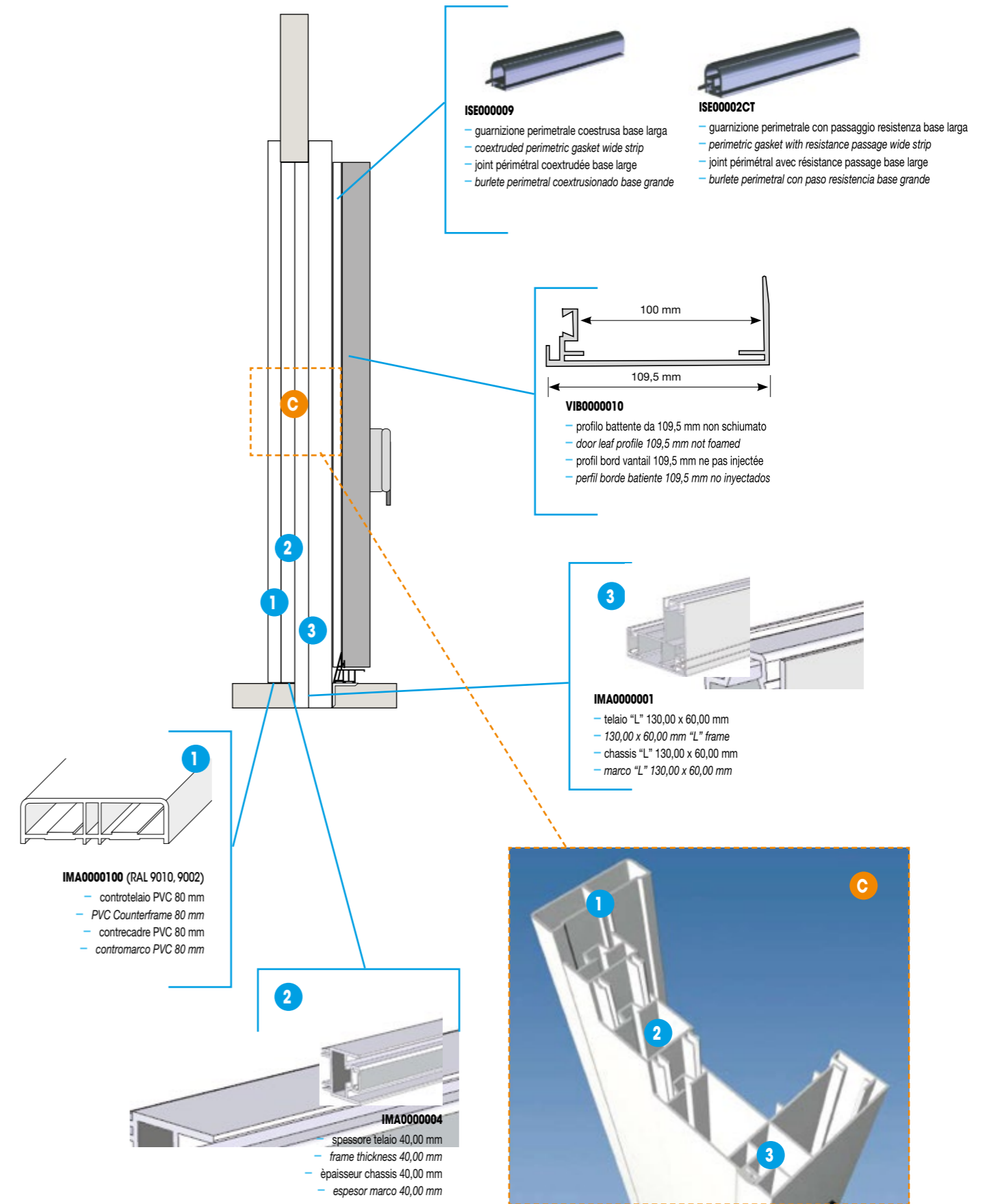

ISE000009

- guarnizione perimetrale coestrusa base larga
- coextruded perimetric gasket wide strip
- joint périphérique coextrudée base large
- burlete perimetral coextrusionado base grande

ISE00002CT

- guarnizione perimetrale con passaggio resistenza base larga
- perimetric gasket with resistance passage wide strip
- joint périphérique avec résistance passage base large
- burlete perimetral con paso resistencia base grande

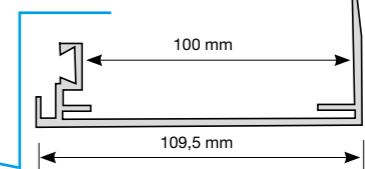

VIB0000010

- profilo battente da 109,5 mm non schiumato
- door leaf profile 109,5 mm not foamed
- profil bord vantail 109,5 mm ne pas injectée
- perfil borde batiente 109,5 mm no injectados

3

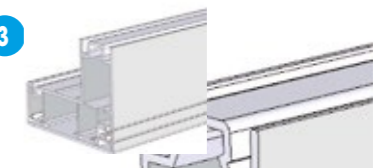

IMA0000001

- telaio "L" 130,00 x 60,00 mm
- 130,00 x 60,00 mm "L" frame
- chassis "L" 130,00 x 60,00 mm
- marco "L" 130,00 x 60,00 mm

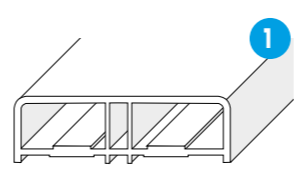

IMA0000100 (RAL 9010, 9002)

- controtelaio PVC 80 mm
- PVC Counterframe 80 mm
- contrecadre PVC 80 mm
- contromarco PVC 80 mm

2

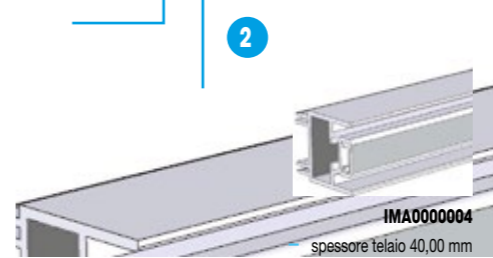

IMA0000004

- spessore telaio 40,00 mm
- frame thickness 40,00 mm
- épaisseur chassis 40,00 mm
- espesor marco 40,00 mm

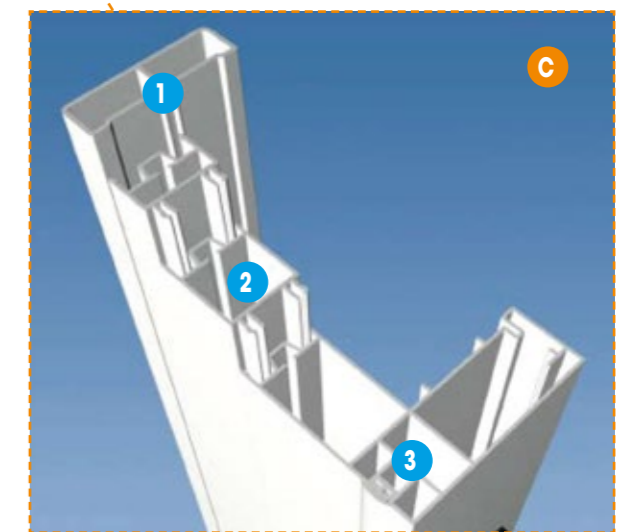

PORTE SU CERNIERA

DOORS ON HINGES / PORTES SUR CHARNIÈRE / PUERTAS SOBRE BISAGRA

DOPPIO BATTENTE E TELAIO DOUBLE DOORBLADE AND FRAME

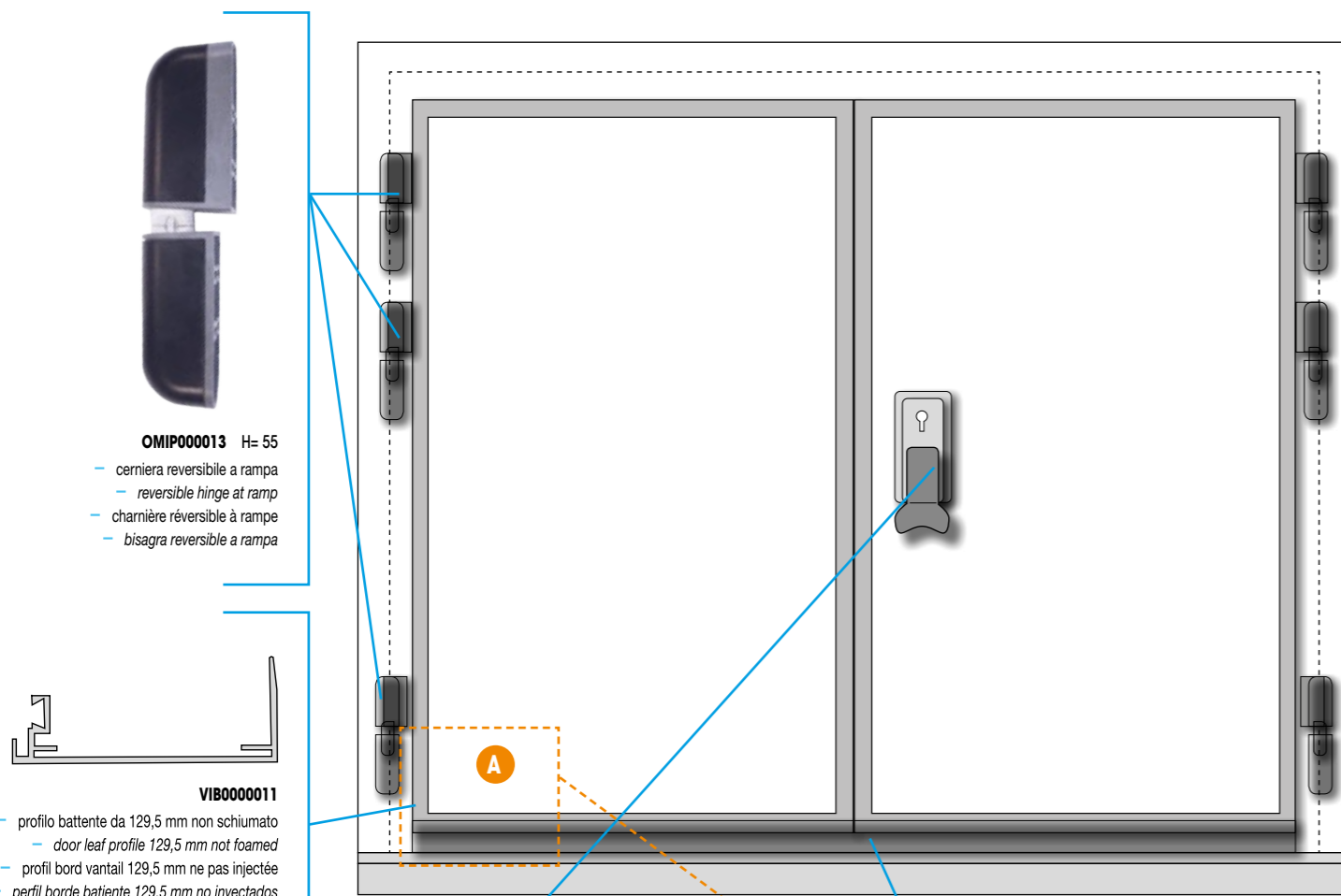

OMIP000013 H= 55

- cerniera reversibile a rampa
- reversible hinge at ramp
- charnière réversible à rampe
- bisagra reversible a rampa

VIB0000011

- profilo battente da 129,5 mm non schiumato
- door leaf profile 129,5 mm not foamed
- profil bord vantail 129,5 mm ne pas injectée
- perfil borde batiente 129,5 mm no inyectados

JUR0000001

- kit maniglia esterna + Interna + tiranteria con serratura
- kit ext + int handle + accessories with key
- Kit poignée ext + int + accessoires avec clé
- Kit cierre ext + int + accesorios con llave

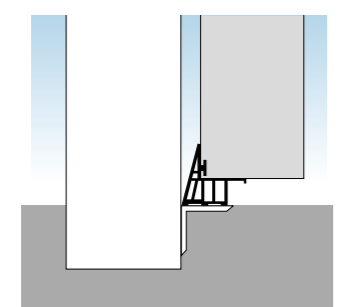

- SOGLIA A FILO PAVIMENTO IN MURATURA
- FLOOR LEVEL THRESHOLD
- SEUIL PLANCHER SEUIL
- UMBRAL A RAS DEL SUELO A MURO

ISE000007

- guarnizione inferiore base larga
- lower gasket wide strip
- joint inférieur base large
- burlete inferior base grande

ISE000011

- guarnizione inferiore con passaggio resistenza
- lower gasket with heating cable passage
- joint inférieur avec résistance passage
- burlete inferior puerta con paso resistencia

62

PORTE SU CERNIERA

DOORS ON HINGES / PORTES SUR CHARNIÈRE / PUERTAS SOBRE BISAGRA

DOPPIO BATTENTE E TELAIO DOUBLE DOORBLADE AND FRAME

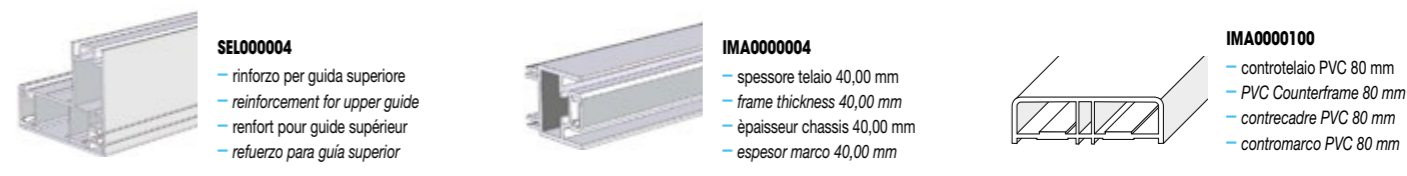

SEL000004

- rinforzo per guida superiore
- reinforcement for upper guide
- renfort pour guide supérieur
- refuerzo para guía superior

IMA0000004

- spessore telaio 40,00 mm
- frame thickness 40,00 mm
- épaisseur chassis 40,00 mm
- espesor marco 40,00 mm

IMA0000100

- controtelaio PVC 80 mm
- PVC Counterframe 80 mm
- contrecadre PVC 80 mm
- contramarca PVC 80 mm

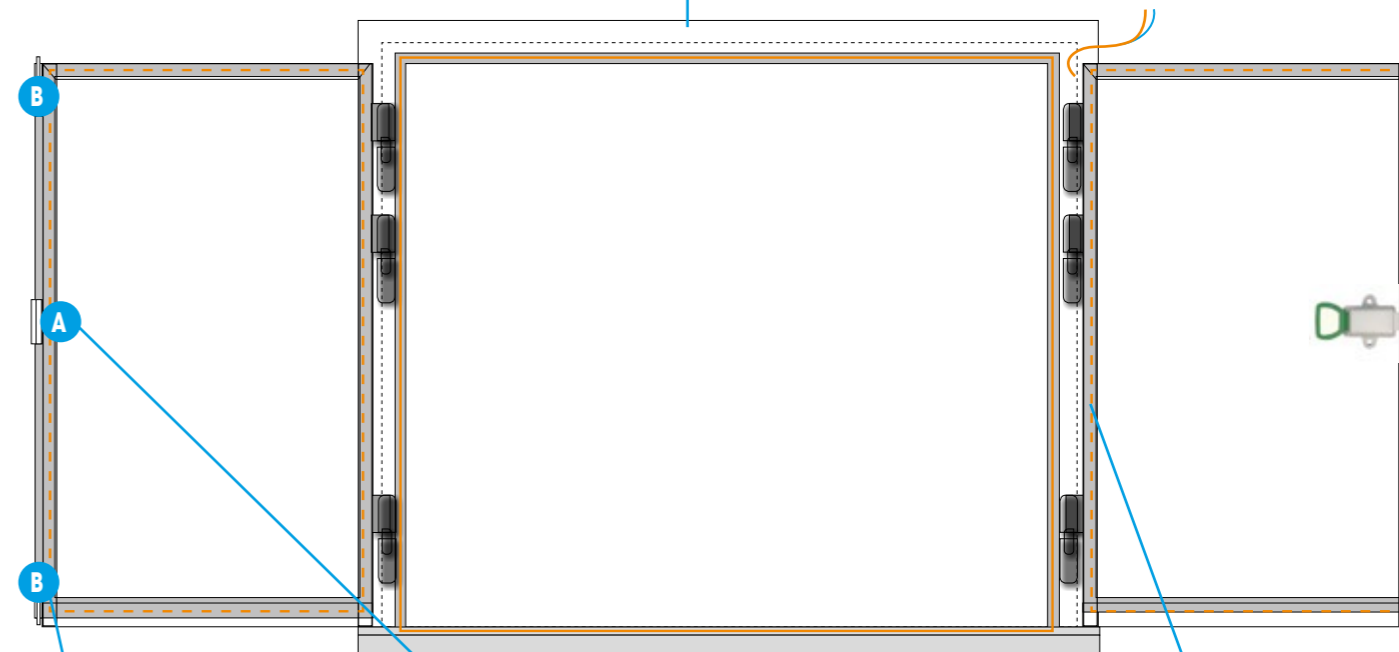

A



OMIPMC0020

- riscontro registrabile
- adjustable stiker
- repère réglable
- elemento de contacto regulable



COM100x50x5

- angolare 100x50 mm
- angular 100x50 mm
- angulaire 100x50 mm
- angular 100x50 mm

ISE000009

- guarnizione perimetrale coestrusa base larga
- coextruded perimetric gasket wide strip
- joint périphérique coextrudée base large
- burlete perimetral coextrusionado base grande



ISE00002CT

- guarnizione perimetrale con passaggio resistenza base larga
- perimetric gasket with resistance passage wide strip
- joint périphérique avec résistance passage base large
- burlete perimetral con paso resistencia base grande

B



ODA0000020

- chiavistello di blocco acciaio inox
- stainless steel for blocking
- verrou a barre cylindrique inox
- bloque de enganche de acero

63

BATTENTE E TELAIO
DOORBLADE AND FRAME

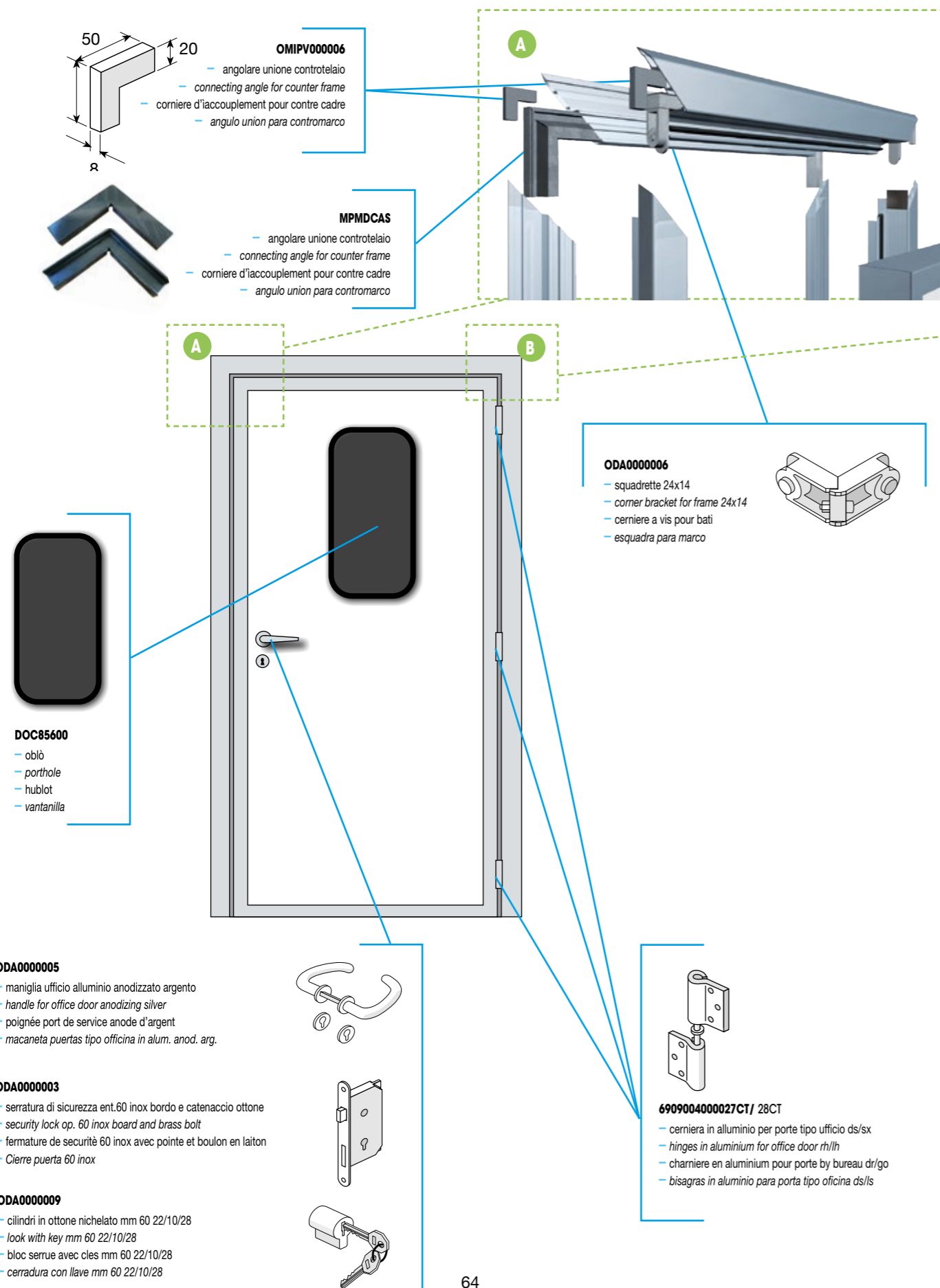

BATTENTE E TELAIO
DOORBLADE AND FRAME

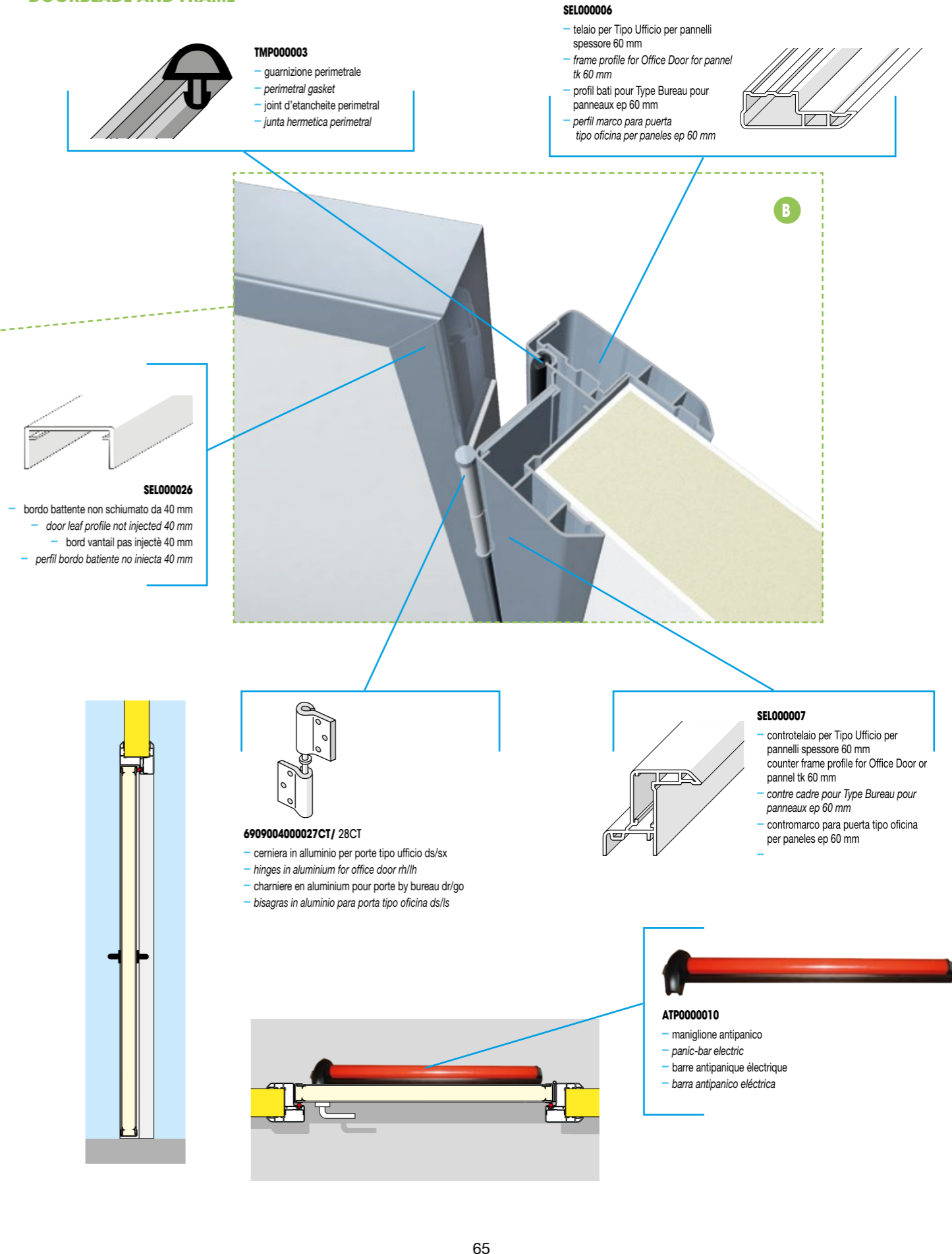

PORTE VA E VIENI

PUSH & PULL DOORS / PORTES VA-ET-VIEN / PUERTAS DE VAIVÉN

COLDTECH

BATTENTE E TELAIO DOORBLADE AND FRAME



OMP000016

- cerniera PVC bassa VA & VIENI con blocco a 90°
- PVC hinge low for push&pull door with 90° block
- charnière PVC faible pour VA-ET-VIEN avec blocage 90°
- bisagra PVC bajo para VAIVÉN con bloqueo 90°

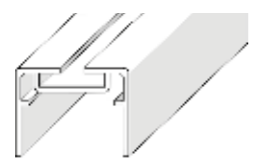

SEL000035

- profilo in alluminio per porte non schiumate
- aluminium profile for doors not foam
- profil en aluminium pour portes pas injectée
- perfil de aluminio para puertas no inyectados

DOC85600

- Oblò ovale 663 x 343 mm
- oval window 663 x 343 mm
- oval hublot 663 x 343 mm
- vantaila 663 x 343 mm

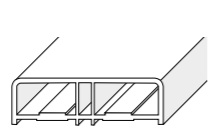
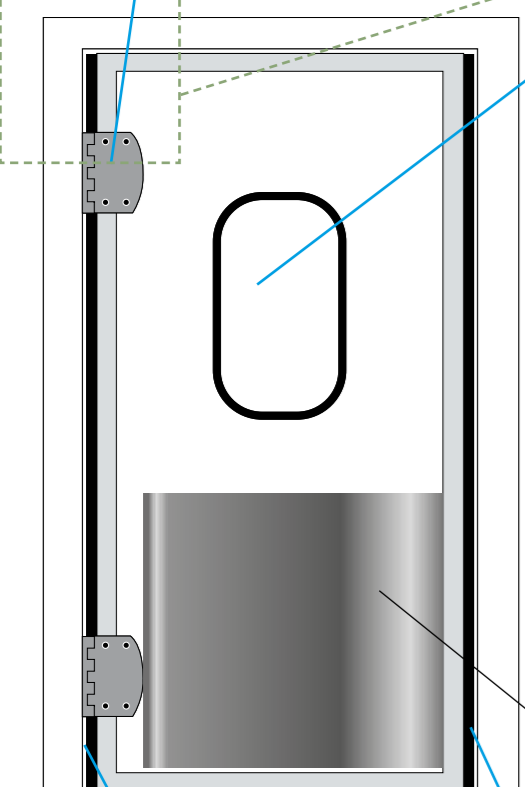

IMA0000100

- controtelaio PVC 80 mm
- PVC Counterframe 80 mm
- contrecadre PVC 80 mm
- contromarco PVC 80 mm

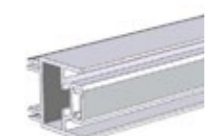

IMA0000004

- spessore telaio 40,00 mm
- frame thickness 40,00 mm
- épaisseur chassis 40,00 mm
- espesor marco 40,00 mm



IMA0000001

- telaio "L" 130,00 x 60,00 mm
- 130,00 x 60,00 mm "L" frame
- chassis "L" 130,00 x 60,00 mm
- marco "L" 130,00 x 60,00 mm

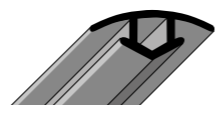

TMP000005

- profilo ad "H"
- pvc "H" profile
- profile "H" en pvc
- perfil "H" en pvc



6909005000053

- pinna H = 40,00 mm coestrusa
- coextruded fin H = 40,00 mm
- aileron H = 40,00 mm coextrudé
- aleta H = 40,00 mm coextrusionada



6909005000052

- pinna H = 32,00 mm coestrusa
- coextruded fin H = 32,00 mm
- aileron H = 32,00 mm coextrudé
- aleta H = 32,00 mm coextrusionada

SELP000303

- paracolpi
- bumpers
- butoirs
- parachoques

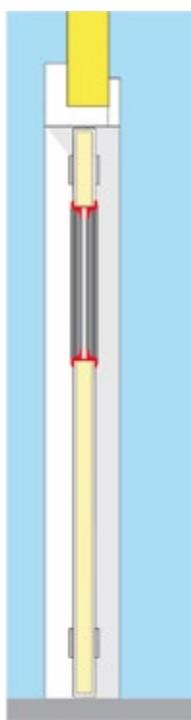

PORTE VA E VIENI

PUSH & PULL DOORS / PORTES VA-ET-VIEN / PUERTAS DE VAIVÉN

COLDTECH

DOPPIO BATTENTE E TELAIO DOUBLE DOORBLADE AND FRAME

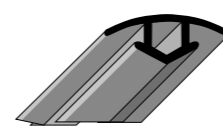

TMP000005

- profilo ad "H"
- pvc "H" profile
- profile "H" en pvc
- perfil "H" en pvc

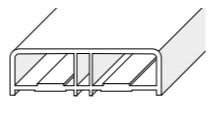

IMA0000100

- controtelaio PVC 80 mm
- PVC Counterframe 80 mm
- contrecadre PVC 80 mm
- contromarco PVC 80 mm



IMA0000004

- spessore telaio 40,00 mm
- frame thickness 40,00 mm
- épaisseur chassis 40,00 mm
- espesor marco 40,00 mm



IMA0000001

- telaio "L" 130,00 x 60,00 mm
- 130,00 x 60,00 mm "L" frame
- chassis "L" 130,00 x 60,00 mm
- marco "L" 130,00 x 60,00 mm

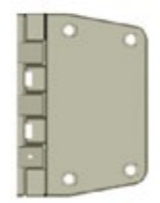

OMP000016

- cerniera PVC bassa VA & VIENI con blocco a 90°
- PVC hinge low for push&pull door with 90° block
- charnière PVC faible pour VA-ET-VIEN avec blocage 90°
- bisagra PVC bajo para VAIVÉN con bloqueo 90°



B

6909005000052

- pinna H = 32,00 mm coestrusa
- coextruded fin H = 32,00 mm
- aileron H = 32,00 mm coextrudé
- aleta H = 32,00 mm coextrusionada

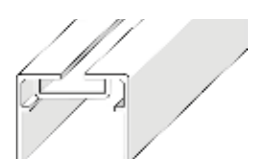

SEL000035

- profilo in alluminio per porte non schiumate
- aluminium profile for doors not foam
- profil en aluminium pour portes pas injectée
- perfil de aluminio para puertas no inyectados

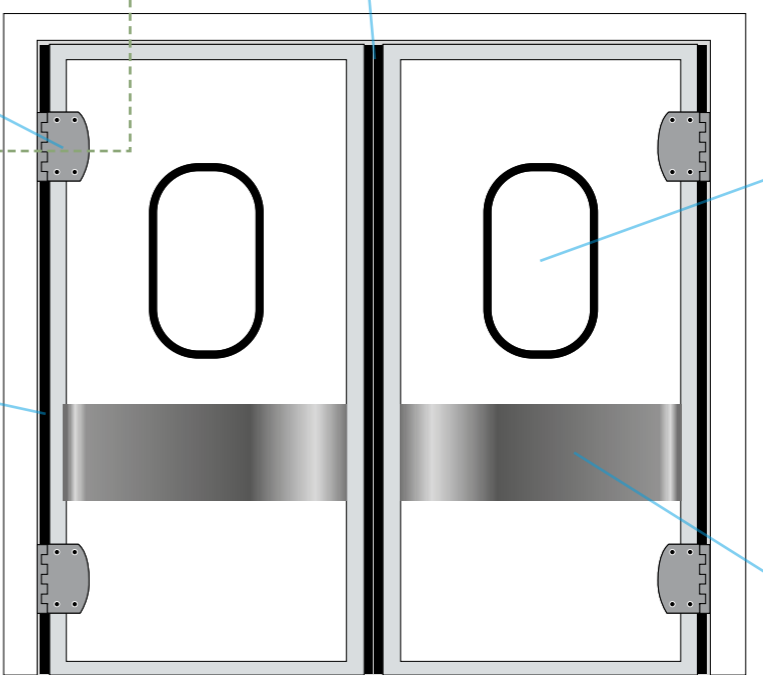

6909005000053

- pinna H = 40,00 mm coestrusa
- coextruded fin H = 40,00 mm
- aileron H = 40,00 mm coextrudé
- aleta H = 40,00 mm coextrusionada



DOC85600

- Oblò ovale 663 x 343 mm
- oval window 663 x 343 mm
- oval hublot 663 x 343 mm
- vantaila 663 x 343 mm



- paracolpi
- bumpers
- butoirs
- parachoques

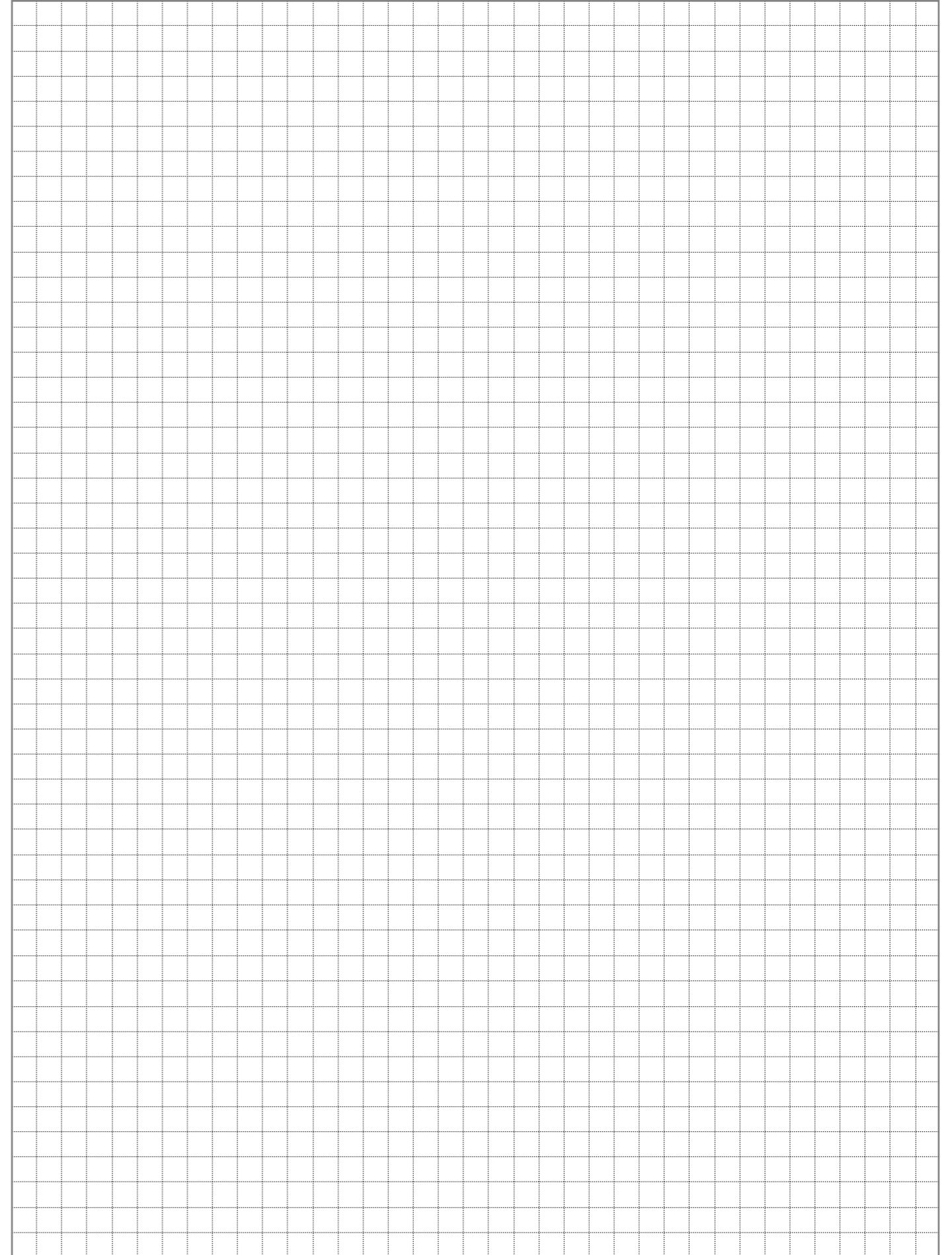
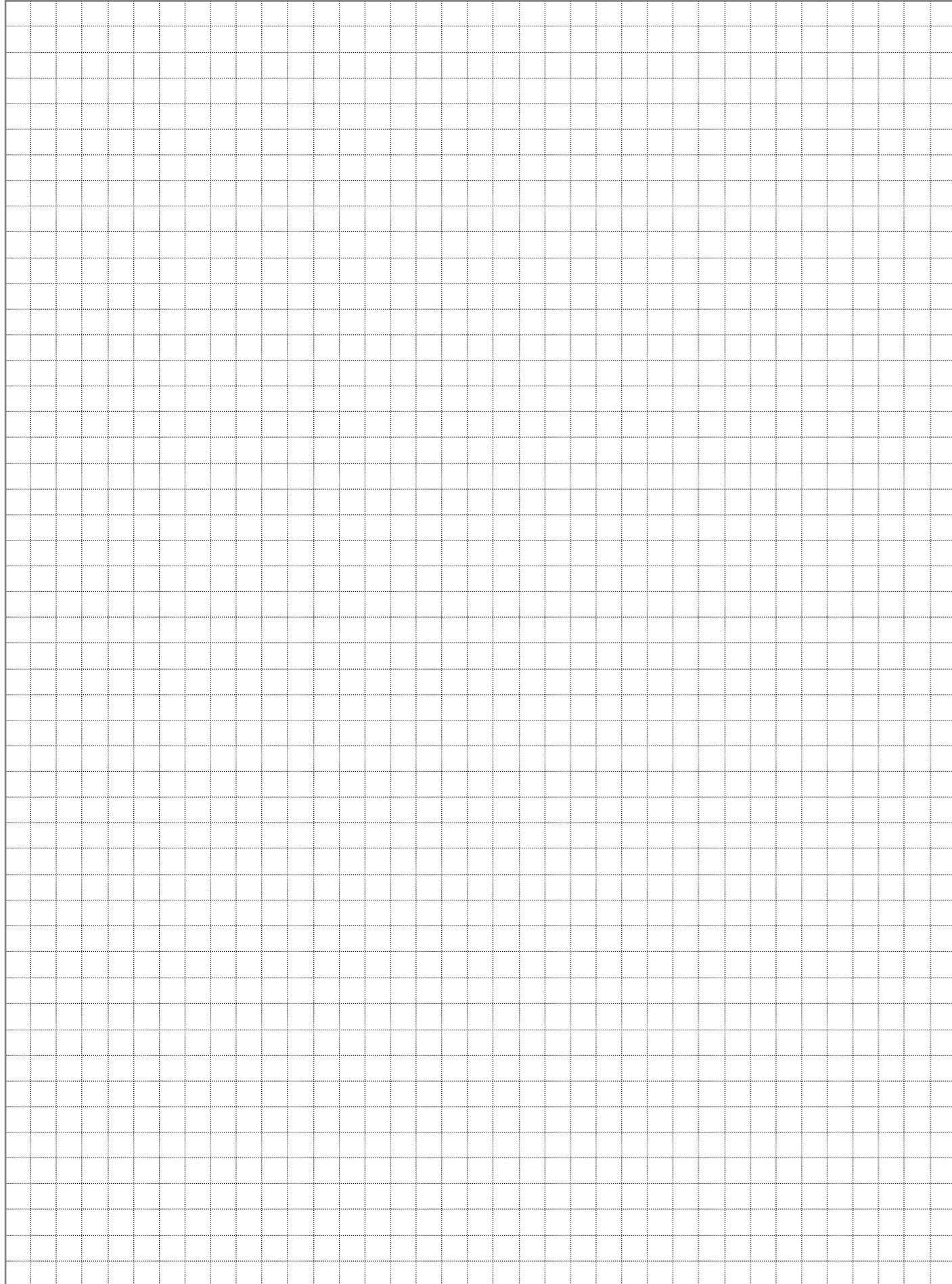



COLDTECH S.R.L.

SEDE LEGALE

C.so Francia 274
10093 Collegno (TO) - Italy
P.IVA 09393210019

coldtech@coldtech.it

SEDE OPERATIVA

Via Rivera 136/2
10040 Almese (TO) - Italy
Tel. +39 011 9370518



coldtech.tech

